

IEI Computer on Modules

A computer-on-module (COM) is a type of single-board computer (SBC), a subtype of an embedded computer system. An extension of the concept of system on chip (SoC) and system in package (SiP), COM lies between a full-up computer and a microcontroller in nature.

Design

Computer-on-modules are complete embedded computers built on a single circuit board. The design is centered on a CPU or a microprocessor with RAM, input/output controllers and all other features needed to be a functional computer on the one board. However, unlike a single-board computer, the Computer-on-module will usually lack the standard connectors for any input/output peripherals to be attached directly to the board. The module will usually need to be mounted on a carrier board (or baseboard) which breaks the bus out to standard peripheral connectors. Some Computer-on-modules also include peripheral connectors and/or can be used without a carrier.

A Computer-on-module solution offers a dense package computer system for use in small or specialized applications requiring low power consumption or small physical size as is needed in embedded systems.

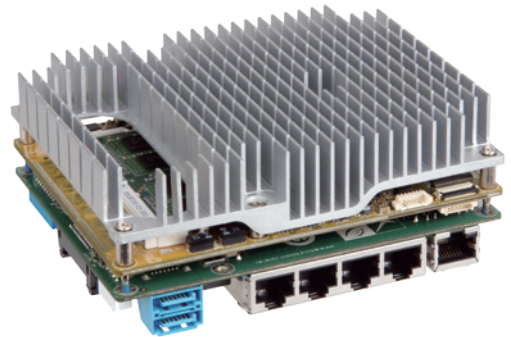

Typical Applications

■ High Density



Smart Camera



Speed Camera



Mobile Device

■ Automation & Robot Controller



Robot Controller



CNC

IEI Computer on Module Form Factors



**COM Express
Type 10**

Mini: 84 mm x 55 mm



**COM Express
Type 6**

Compact: 95 mm x 95 mm



**COM Express
Type 6**

Basic: 125 mm x 95 mm

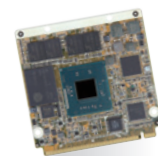

Qseven 2.0

70 mm x 70 mm

1

Industrial
Computing
Solutions

2

Video
Capture
Solutions

3

Industrial
Computer
Chassis

4

Open
Frame
Monitor

5

Power Supply/
Peripherals

6

All-in-One
System

Computer on Module Selection Guide

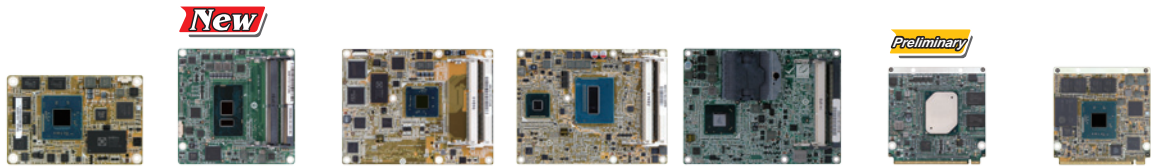

| Computer on Module | COM Express Type 10 | COM Express Type 6 | COM Express Type 6 | COM Express Type 6 | COM Express Type 6 | Qseven 2.0 | Qseven 2.0 |
|------------------------------|---|--|--|--|---|--|--|
| COM Express Size | Mini: 84 mm x 55 mm | Compact: 95 mm x 95 mm | Basic: 125 mm x 95 mm | Basic: 125 mm x 95 mm | Basic: 125 mm x 95 mm | 70 mm x 70 mm | 70 mm x 70 mm |
| Model Name | ICE-BT-T10 ICE-BT-T10W2 | ICE-ULT3 | ICE-BT-T6 | ICE-QM871 | ICE-QM770 | iQ7-AL iQ7-ALW | iQ7-BT-E38001 iQ7-BT-E38001W2 |
| CPU Socket | On board | On board | On board | On board | Socket G2 | On Board | On board |
| CPU Type | Intel® Atom™/ Celeron® on-board SoC | Intel® Skylake ULT On board SoC | Intel® Atom™/ Celeron® on-board SoC | 4th Generation 22nm Intel® Core™ i7/i5/i3 and Celeron® mobile processor | 2nd & 3rd Generation Intel® Core™ i7/i5/i3 and Celeron® mobile processor | Intel® Atom™/ Celeron®/Pentium® on-board SoC | Intel® Atom™/ Celeron® on-board SoC |
| Chipset | Intel® Atom™/ Celeron® on-board SoC | Intel® Skylake ULT | Intel® Atom™/ Celeron® on-board SoC | Intel® QM87 | Intel® QM77 | Intel® Atom™/ Celeron®/Pentium® on-board SoC | Intel® Atom™/ Celeron® on-board SoC |
| Memory | 2 GB soldered down 1066/1333 MHz DDR3L memory (up to 8 GB) | Two 260-pin 2133/1867 MHz dual-channel DDR4 SDRAM Unbuffered DIMM supported (system max. 32GB) | Two 204-pin 1066/1333 MHz dual- channel DDR3L SO- DIMM supported (system max. 8 GB) | Two 204-pin 1066/1333 MHz dual- channel DDR3L SO- DIMM supported (system max. 16 GB) | Two 204-pin 1066/1333 MHz dual- channel DDR3L SO- DIMM supported (system max. 16 GB) | 4 GB soldered down 1600/1333 MHz DDR3L memory | 2 GB soldered down 1066/1333 MHz DDR3L memory (up to 4 GB) |
| Display Interface | Dual display supported 1 x VGA 1 x DDI 1 x eDP | Triple display supported 2 x DDI: DisplayPort/ HDMI/DVI 1 x DDI: Embedded DP (Option with 1 x Dual Channel LVDS 18/24 bit via CH7511B) | Dual display supported 1 x VGA 1 x DDI 1 x 18/24-bit dual- channel LVDS | Triple display supported 1 x VGA 3 x DDI 1 x 18/24-bit dual- channel LVDS | Triple display supported 1 x VGA 3 x DDI 1 x 18/24-bit dual- channel LVDS | Triple display supported 1 x 18/24-bit dual- channel LVDS 1 x eDP/LVDS-A channel (optional) 1 x DDI | Dual display supported 1 x DDI 1 x 18/24-bit dual- channel LVDS |
| Ethernet | LAN1: Intel® I210 PCIe controller | LAN1: Intel® I219LM | LAN1: Intel® I210 PCIe controller | LAN1: Intel® I217LM Clarkville-V with Intel® AMT 9.0 support | LAN1: Intel® Intel® 82579LM with Intel® AMT 8.0 support | LAN1: Intel® I210 PCIe controller | LAN1: Intel® I210 PCIe controller |
| I/O Interface | 1 x I ² C 1 x SMBus 1 x LPC 1 x USB 3.0 2 x Serial port (TX & RX) 4 x USB 2.0 | 2 x RS-232 (2-Wire) to base board 4 x USB 2.0 to base board 4 x USB 3.0 to base board (with 4 x USB 2.0) | 1 x I ² C 1 x LPC 1 x SMBus 2 x Serial port (TX & RX) 4 x USB 3.0 7 x USB 2.0 | 1 x I ² C 1 x LPC 1 x SMBus 2 x Serial port (TX & RX) 4 x USB 3.0 8 x USB 2.0 | 1 x I ² C 1 x LPC 1 x SMBus 2 x Serial port (TX & RX) 4 x USB 3.0 8 x USB 2.0 | 1 x LPC 1 x SDIO 1 x SMBus 1 x USB 3.0 3 x I ² C 6 x USB 2.0 | 1 x LPC 1 x SDIO 1 x SMBus 1 x USB 3.0 3 x I ² C 6 x USB 2.0 |
| Driver Interface | 2 x SATA 3G/s Optional soldered down SSD up to 64 GB (SATA port 1) | 2 x SATA 6GB/s signal to base board eMMC 5.0 (optional) | 2 x SATA 3G/s Optional soldered down SSD up to 64 GB (SATA port 1) | 4 x SATA 6G/s | 4 x SATA 6G/s | 2 x SATA 6G/s Optional soldered down 8GB eMMC 5.0 | 2 x SATA 3G/s Optional soldered down SSD up to 64 GB (SATA port 1) |
| Audio | High-definition Audio interface | | | | | | |
| Power Consumption | 12V@0.43A, Vcore_12V@0.9 A (Intel® Atom™ E3845 CPU with 2 GB 1333 MHz DDR3L memory) | 12V@2.57A, 5VSB@0.04A, 5V@0.02A (Intel® Core™ i7- 6600U with two 8GB 2400 MHz DDR4 memory) | 12V@0.54A, Vcore_12V@0.95A (Intel® Celeron® J1900 CPU with two 8 GB 1333 MHz DDR3 memory) | 12V@3.70A (Intel® Core™ i7- 4700EQ 2.4GHz CPU with 8 GB (two 4 GB) 1333 MHz DDR3 memory) | 12V@1.86A, +12V2@3.70A (Intel® Core™ i7- 4700EQ 2.4GHz CPU with 8 GB (two 4 GB) 1333 MHz DDR3 memory) | TBD | 3.3V@0.13A, 5V@0.13A, 12V@1.35A, 5VSB@0.12A (Intel® Atom™ E3845 CPU with 2 GB on- board memory) |
| Watchdog Timer | Software programmable and supports 1~255 sec. system reset | | | | | | |
| Operation Environment | Temperature Range: -20°C ~ 60°C -40°C ~ 85°C (ICE- BT-10-E38001W2) Relative Humidity: 10% ~ 95% non- condensing | Operating Temperature: -20°C ~ 60°C Operating Humidity : 5% ~ 95%, non- condensing | Temperature Range: -20°C ~ 60°C Relative Humidity: 10% ~ 95% non- condensing | Temperature Range: -20°C ~ 60°C Relative Humidity: 10% ~ 95% non- condensing | Temperature Range: -20°C ~ 60°C Relative Humidity: 10% ~ 95% non- condensing | Temperature Range: -20°C ~ 60°C -40°C ~ 85°C (iQ7- AL-ExW2) Relative Humidity: 10% ~ 95% non- condensing | Temperature Range: -20°C ~ 60°C -40°C ~ 85°C (iQ7- BT-E38001W2) Relative Humidity: 10% ~ 95% non- condensing |
| Expansion Slot | 3 x PCIe x1 signal to baseboard | 1 x PCIe x1 signal to base board (Via PCIe x16 channel) 8 x PCIe x1 signal to base board | 5 x PCIe x1 signal to baseboard | 1 x PCIe x16 signal (to baseboard) 7 x PCIe x1 signal (to baseboard) | 1 x PCIe x16 signal (to baseboard) 7 x PCIe x1 signal (to baseboard) | 3 PCIe x1 or 2 PCIe x1 + 1 PCIe x2 signal to baseboard | 3 x PCIe x1 signal to baseboard |

1

Industrial
Computing
Solutions

2

Video
Capture
Solutions

3

Industrial
Computer
Chassis

4

Open
Frame
Monitor

5

Power Supply/
Peripherals

6

All-in-One
System

IEI COM Express Series

COM Express is a computer-on-module (COM) form factor series. It can be integrated in various customized applications. Each COM Express module integrates CPU, memory and common I/O of a PC/AT including USB, audio, graphics, and Ethernet. All I/O signals are mapped to two high density, low profile connectors on the bottom side of the module. The COM Express specification is hosted by PICMG. The ICE (IEI COM Express) modules provide complete performance range for users to choose. With the IEI COM Express baseboard design service, users can quickly enjoy the benefits of modulization and efficiency.

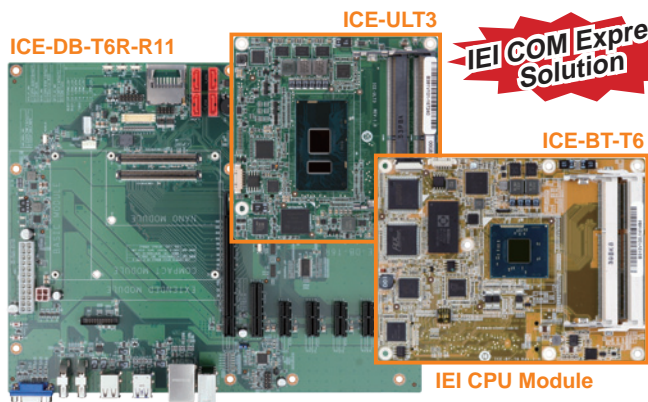

IEI COM Express design baseboard

Transfer your ETX Module to IEI COM Express Solution

COM Express provides PCI Express, dual-channel LVDS, GbE, eight USB and four SATA ports for I/O expansion

| Platform | ETX | COM Express Type 2 Basic Module |
|-----------|------------------------------|---|
| Size | 95 mm x 114 mm | 95 mm x 125 mm |
| VGA | Yes | Yes |
| LCD | TTL or LVDS | Up to 2x single LVDS or dual-channel LVDS |
| SDVO | N/A | Up to 2 SDVO (shared with PCIe x16) |
| Expansion | PCI & ISA | PCIe & PCI |
| Ethernet | 10/100 Mbps | 10/100/1000 Mbps |
| USB | Up to 4 ports | Up to 8 ports |
| SATA | Up to 2 Ports (ETX 3.0 only) | Up to 4 SATA |
| IDE | Up to 2 channels | Up to 1 channel |

COM Express Pinout Types

COM Express, a computer-on-module (COM) form factor, is a highly integrated and compact PC that can be used in a design application much like an integrated circuit component. Each COM Express Module COM integrates core CPU and memory functionality, the common I/O of a PC/AT, USB, audio, graphics (PEG), and Ethernet. All I/O signals are mapped to two high density, low profile connectors on the bottom side of the module.

Types

The COM Express specification is hosted by PICMG. There are seven different pinouts defined in the specification. The most common used pin out is Type 2 and Type 1. The latest pin-outs added in the revision 2.0 of the COM Express specification are Type 6 and Type 10.

| Types | PCIe Lanes | PEG/SDVO | Display | SATA | LAN | PCI | IDE | USB 2.0 | USB 3.0 |
|---------|------------|----------|-----------------------|------|-----|-----|-----|---------|---------|
| Type 1 | Up to 6 | × | VGA, LVDS | 4 | 1 | × | × | 8 | × |
| Type 10 | Up to 4 | /1 | DDI, LVDS | 2 | 1 | × | × | 8 | 2 |
| Type 2 | Up to 22 | 1/2 | VGA, LVDS, PEG, SDVO | 4 | 1 | ✓ | × | 8 | × |
| Type 6 | Up to 24 | 1/ | VGA, LVDS, PEG, 3*DDI | 4 | 1 | × | × | 8 | 4 |

The Specification Defines Three Module Sizes:

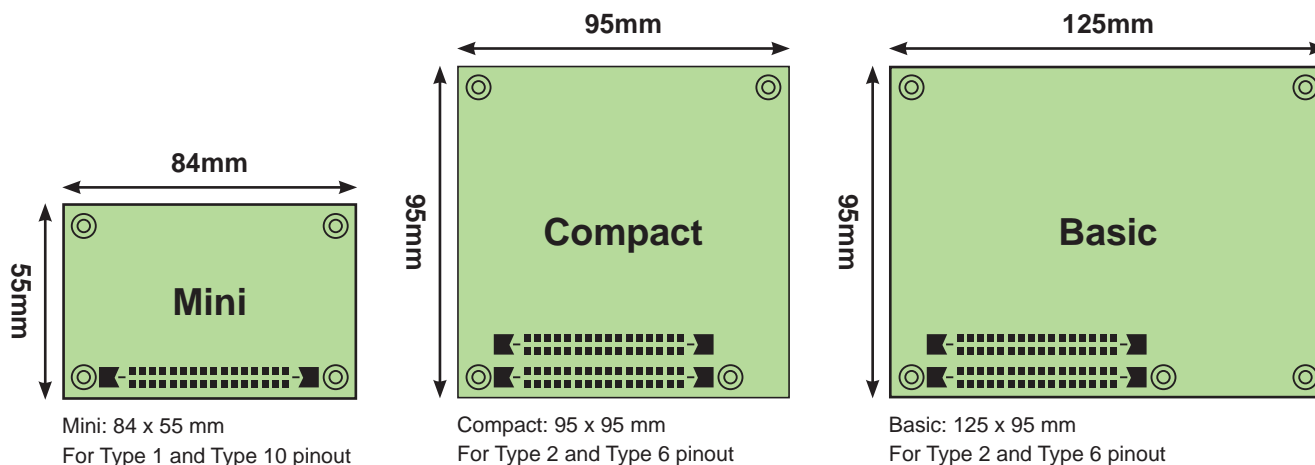

1
Industrial Computing Solutions

2
Video Capture Solutions

3
Industrial Computer Chassis

4
Open Frame Monitor

5
Power Supply/Peripherals

6
All-in-One System

◆ Pinout Comparison of Type 1 and Type 10

Type 1 Pinout

| | | | | | | | | | |
|---|--------------------------|--------------|-------|-----------------|-----------------|--------|--------|------|-----|
| B | LPC SMB I ² C | 4 ports SATA | Audio | 8 ports USB 2.0 | 6 lanes PCIe x1 | LVDS B | VGA | 5VSB | 12V |
| A | GBE | | | | | LVDS A | Others | SPI | 12V |

Type 10 Pinout

| | | | | | | | | | | | |
|---|--------------------------|--------------|-----------------|-------|-----------------|-----------------|-------------|--------|--------|------|----------------|
| B | LPC SMB I ² C | 2 ports SATA | 2 ports USB 3.0 | Audio | 8 ports USB 2.0 | 4 lanes PCIe x1 | Reserve Pin | DDI | | 5VSB | 12V |
| A | GBE | | | | | | | LVDS A | Others | SPI | 2 ports serial |

◆ Pinout Comparison of Type 2 and Type 6

Type 2 Pinout

| | | | | |
|---|----------|-----|-----------------|-----|
| D | PATA IDE | PCI | PCIe x16 (SDVO) | 12V |
| C | | | | |

| | | | | | | | | | |
|---|--------------------------|--------------|-------|-----------------|-----------------|--------|--------|------|-----|
| B | LPC SMB I ² C | 4 ports SATA | Audio | 8 ports USB 2.0 | 6 lanes PCIe x1 | LVDS B | VGA | 5VSB | 12V |
| A | GBE | | | | | LVDS A | Others | SPI | 12V |

Type 6 Pinout

| | | | | | | | |
|---|---------------------|------------------|-------|-------|-------|----------|-----|
| D | 4 ports USB 3.0/2.0 | 2 lanes PCIe x 1 | DDI 1 | DDI 2 | DDI 3 | PCIe x16 | 12V |
| C | | | | | | | |

| | | | | | | | | | |
|---|--------------------------|--------------|-------|-----------------|-----------------|--------|--------|------|--------------------|
| B | LPC SMB I ² C | 4 ports SATA | Audio | 8 ports USB 2.0 | 6 lanes PCIe x1 | LVDS B | VGA | 5VSB | 12V |
| A | GBE | | | | | LVDS A | Others | SPI | 2 ports serial TPM |

■ Installing the COM Express

◆ Thermal Design of COM Express

COM Express definition includes a heatspreader that acts as a thermal interface between the COM Express module and the system's cooling solution. The height of a COM Express module, including the heatspreader, has been defined as 18 mm and covers the complete area of the COM Express. All heat generating components are thermally conducted to the heatspreader in order to avoid hot spots.

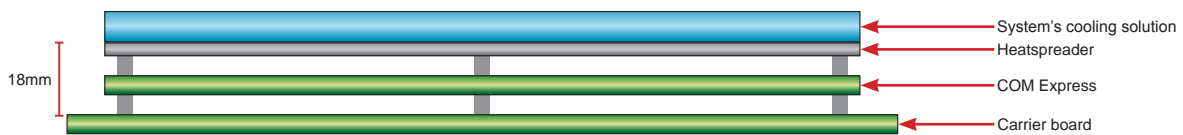

1. Installing the COM Express

Firmly insert the COM Express into the COM Express socket.

2. Installing the heatspreader

A heatspreader must be installed on the COM Express. Thermal pads must be smeared on the lower side of the heatspreader before it is mounted on the COM Express. Heatspreaders are mounted on the CPU, Northbridge and Southbridge chipsets to ensure the operating temperature of these chips remain low.

Step 1.

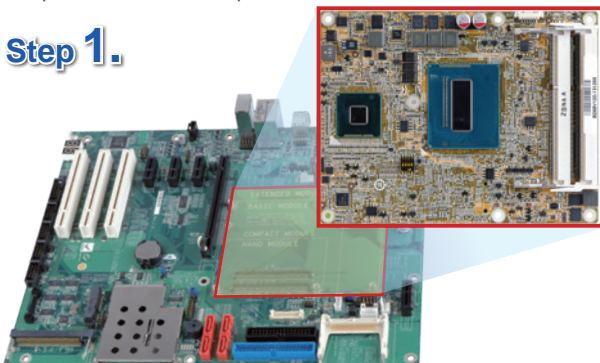

▲ Installing the COM Express

Step 2.

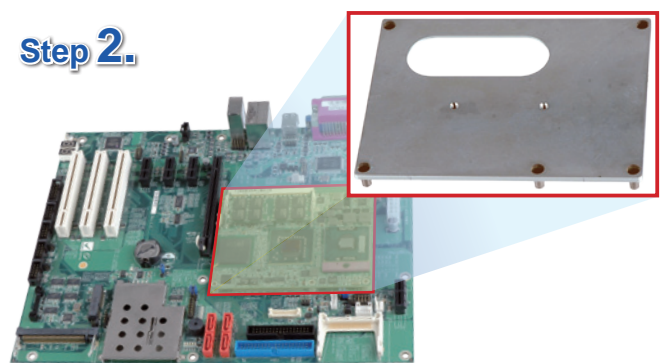

▲ Installing the heatspreader

3. Installing the system's cooling solution

In addition to the heatspreader, COM Express needs another heatsink or other thermal solution to cool down the COM Express.

Before installing the system's cooling solution, make sure that you have properly applied thermal interface material to the heatspreader.

Operating Temperature

The maximum and minimum operating temperatures for the standard COM Express are listed below.

- Minimum Operating Temperature: 0°C (32°F)
- Maximum Operating Temperature: 60°C (140°F)

WARNING:

Never run the embedded module without the heat sink. The heatspreader plate shipped with the COM Express acts as a thermal interface between the module and the heat sink. The heat sink must be installed on the heatspreader plate to maintain proper operating temperatures. Make sure to maintain the heatspreader plate temperature under 60°C in operation.

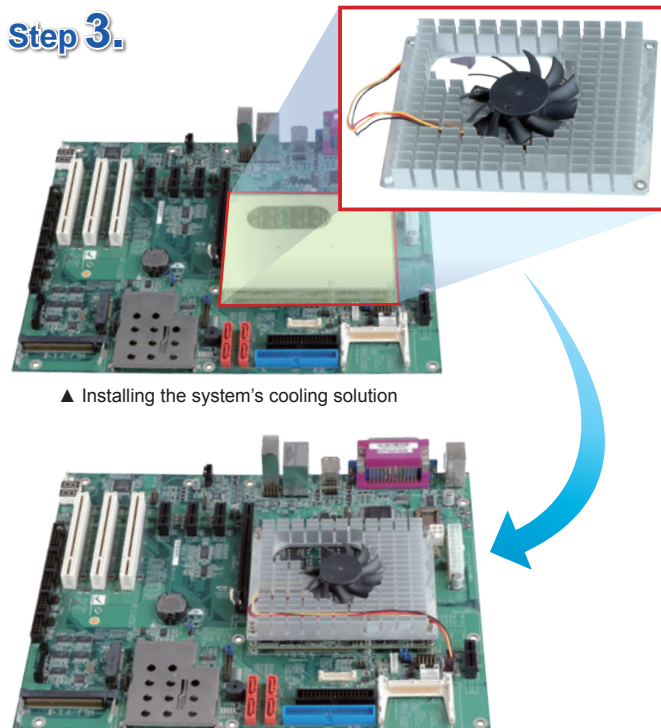

▲ Installing the system's cooling solution

Benefits

A: High Compatibility

- IEI ICE modules follow standard COM Express design guide and have high compatibility
- ICE modules are compatible with all baseboards compliant with COM Express specifications
- Complete performance level for customers' choice

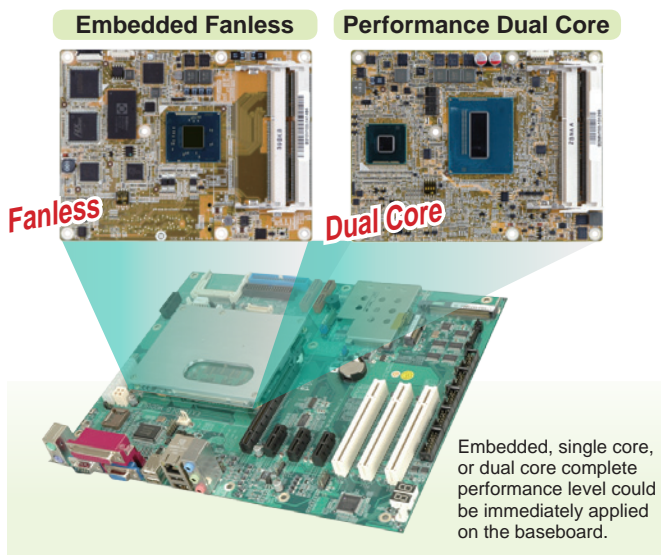
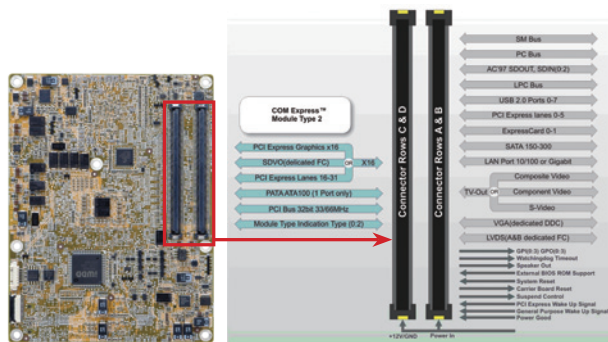

B: Strong Support

- With strong R&D resources, IEI provides customers innovative leading products and service to drive successful experience.
- IEI provides complete turnkey solutions from hardware, software and industrial BIOS design support.

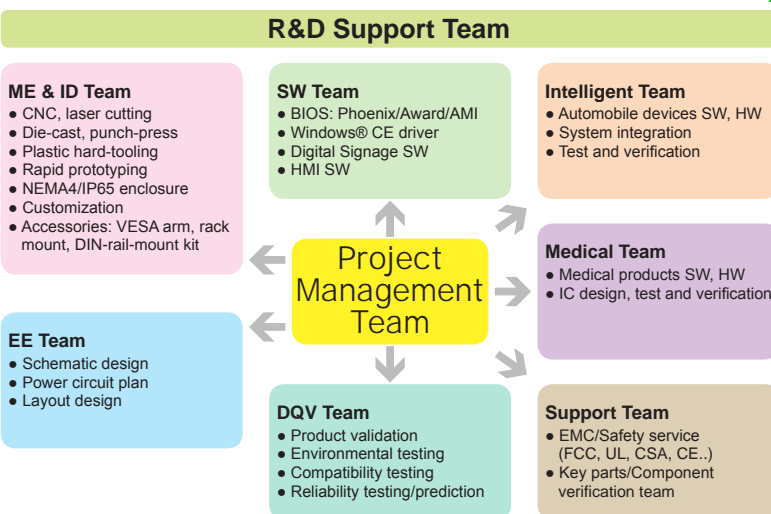
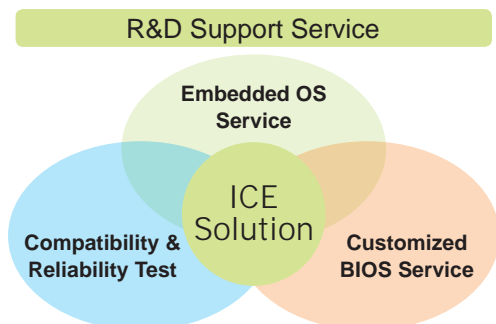

- 1 Industrial Computing Solutions
- 2 Video Capture Solutions
- 3 Industrial Computer Chassis
- 4 Open Frame Monitor
- 5 Power Supply/Peripherals
- 6 All-in-One System

TYPE 6

ICE-ULT3

COM Express Compact size Type 6 Module, 6th Generation Intel® Core™ ULT Processor, DDR4, VGA, LVDS, DDI, GbE, SATA 6Gb/s, USB 3.0 and HD Audio, RoHS

New

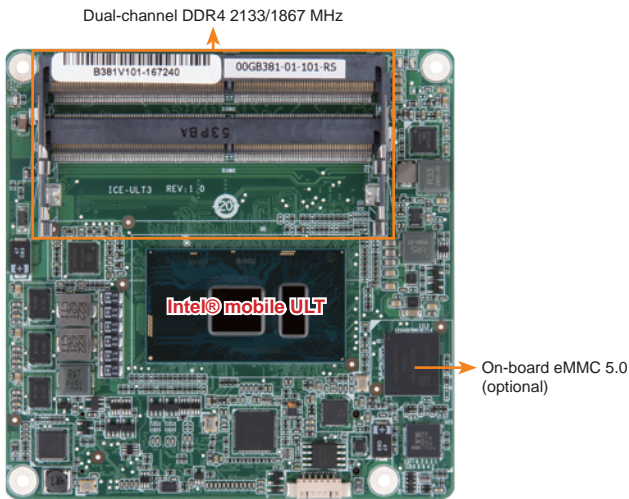

One piece heat sink for COM Express Basic Size provides better thermal solution



Specifications

- ◆ CPU
 - 6th generation Intel® mobile ULT on-board SoC
 - Intel® Core™ i7-6600U (up to 3.4GHz, dual-core, 4MB cache, TDP=15W)
 - Intel® Core™ i5-6300U (up to 3.0GHz, dual-core, 3MB cache, TDP=15W)
 - Intel® Core™ i3-6100U (up to 2.3GHz, dual-core, 3MB cache, TDP=15W)
 - Intel® Celeron® processor 3955U (up to 2.0GHz, dual-core, 2MB cache, TDP=15W)
 - Intel® Celeron® processor 3855U (up to 1.6GHz, dual-core, 2MB cache, TDP=15W)
- ◆ Memory
 - Two 260-pin 2133/1867 MHz dual-channel DDR4 non-ECC unbuffered SO-DIMMs support up to 32GB
- ◆ BIOS
 - UEFI BIOS
- ◆ Graphic Engine
 - Intel® HD Graphics Gen 9 support for DX11/12, OCL 2.x, OGL 4.3/4.4, ES 2.0 Decode/Encode for HEVC, VP8, VP9 2, VDENC
- ◆ Display Output
 - 1 x DDI: DisplayPort/HDMI/DVI (up to 3840x2160@60Hz)
 - 1 x DDI: DisplayPort/HDMI/DVI (up to 3840x2160@60Hz) (Option with 1 x CRT via CH7517) (up to 1920x1200@60Hz)
 - 1 x DDI: Embedded DP (up to 3840x2160@60Hz) (Option with 1 x Dual Channel LVDS 18/24 bit via CH7511B) (up to 1920x1200@60Hz)
- ◆ Ethernet
 - Intel® Clarkville-V I219LM Support Intel® AMT 11.0
- ◆ Embedded Controller
 - TBD
- ◆ I/O Interface
 - 2 x RS-232 (2-Wire) to base board
 - 4 x USB 2.0 to base board
 - 4 x USB 3.0 to base board (with 4 x USB 2.0)
 - 2 x SATA 6Gb/s signal to base board
- ◆ Audio
 - High definition audio interface
- ◆ SMBus
 - YES, to base board
- ◆ I²C
 - YES, to base board
- ◆ LPC
 - YES, to base board
- ◆ Expansion
 - 1 x PCIe x1 signal to base board (Via PCIe x16 channel)
 - 8 x PCIe x1 signal to base board
- ◆ Watchdog Timer
 - Software programmable support 1~255 sec. system reset
- ◆ eMMC
 - eMMC 5.0 (optional)
- ◆ GPIO
 - 8 bit GPIO, to base board
- ◆ TPM
 - Through base board
- ◆ Power Supply
 - 12V: 12V±5%, 5VSB: 5V±5%, RTC Battery: 2.0-3.3V
- ◆ Power Consumption
 - +12V@2.57A, 5VSB@0.04A, 5V@0.02A (Intel® Core™ i7-6600U with two 8GB 2400 MHz DDR4 memory)
- ◆ Operating Temperature
 - 20°C ~ 65°C
- ◆ Operating Humidity
 - 5% ~ 95%, non-condensing
- ◆ Dimension
 - 95 mm x 95 mm
- ◆ Weight
 - GW: 60g / NW: 250g

Features

- Intel® Skylake ULT Processors supported
- Intel® HD Graphics technology integrates high-performance graphics and media processing
- Two 260-pin 2133/1867 MHz Dual-Channel DDR4 SDRAM Unbuffered DIMM supported (system max. 32GB)
- 18/24-bit dual-channel LVDS, analog CRT, DDI supported
- IEI One Key Recovery solution allows you to create rapid OS backup and recovery
- Support Intel® AMT 11.0

Dimensions (Unit: mm)

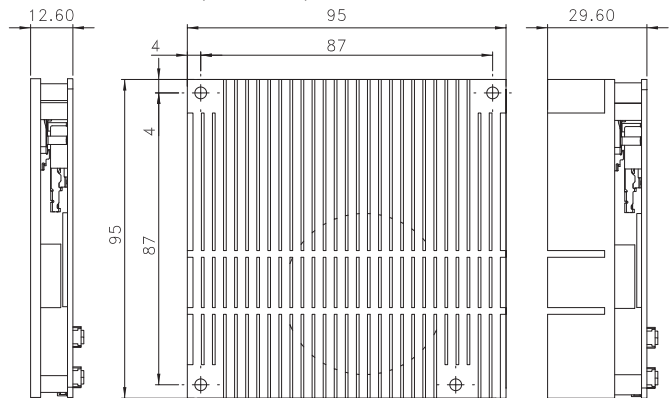

Packing List

| | |
|------------------------------------|---------------|
| 1 x ICE-ULT3 single board computer | 1 x Driver CD |
| 1 x Heatsink | 1 x QIG |

Ordering Information

| Part No. | Description |
|-----------------|--|
| ICE-ULT3-i7-R10 | COM Express Compact size Type 6 Module, 6th Generation Intel® Core™ i7-6600U (15W) on-board Processor (ULT), DDR4, VGA, LVDS, DDI, GbE, USB 3.0, SATA 6Gb/s and HD Audio, RoHS |
| ICE-ULT3-i5-R10 | COM Express Compact size Type 6 Module, 6th Generation Intel® Core™ i5-6300U (15W) on-board Processor (ULT), DDR4, VGA, LVDS, DDI, GbE, USB 3.0, SATA 6Gb/s and HD Audio, RoHS |
| ICE-ULT3-i3-R10 | COM Express Compact size Type 6 Module, 6th Generation Intel® Core™ i3-6100U (15W) on-board Processor (ULT), DDR4, VGA, LVDS, DDI, GbE, USB 3.0, SATA 6Gb/s and HD Audio, RoHS |
| ICE-ULT3-C-R10 | COM Express Compact size Type 6 Module, Intel® Celeron® 3955U (15W) on-board Processor (ULT), DDR4, VGA, LVDS, DDI, GbE, USB 3.0, SATA 6Gb/s and HD Audio, RoHS |
| ICE-ULT3-CE-R10 | COM Express Compact size Type 6 Module, Intel® Celeron® 3855U (15W) on-board Processor (ULT), DDR4, VGA, LVDS, DDI, GbE, USB 3.0, SATA 6Gb/s and HD Audio, RoHS |
| ICE-DB-T6R-11 | Base Board for COM Express Type 6 Module COM.0 Rev. 2.1, support PICMG EAPI R1.0 |

1 Industrial Computing Solutions
 2 Video Capture Solutions
 3 Industrial Computer Chassis
 4 Open Frame Monitor
 5 Power Supply/Peripherals
 6 All-in-One System

TYPE 10

ICE-BT-T10-T10W2

COM Express Rev 2.1 Mini Size Type 10 Module, Intel® 4th Generation Atom™ Processor, VGA, DDI, GbE, SATA 3Gb/s, USB and Audio, -40°C to +85°C and RoHS

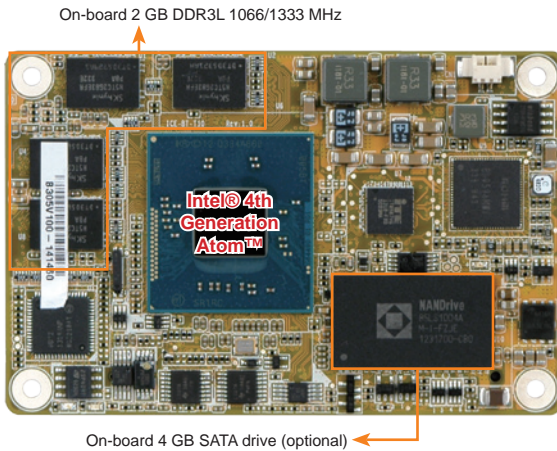

The one-piece heatsink for COM Express Type 10 provides better thermal solution



Specifications

- ◆ CPU
 - Intel® Atom™ E3845 on-board SoC (1.91GHz, quad-core, 2MB cache, TDP=10W)
 - Intel® Atom™ E3825 on-board SoC (1.33GHz, dual-core, 1MB cache, TDP=6W)
 - Intel® Atom™ E3815 on-board SoC (1.46GHz, single-core, 512KB cache, TDP=5W)
- ◆ Memory
 - 2 GB soldered down 1066/1333 MHz DDR3L memory (up to 8 GB)
- ◆ BIOS
 - UEFI BIOS
- ◆ Graphics Engine
 - Intel® HD Graphics Gen 7 Engine with 4 execution units, supports DX11.1, OpenGL 4.2 and OpenCL1.2
- ◆ Display Output
 - 1 x VGA (up to 2560x1600@60Hz)
 - 1 x DDI: DisplayPort/HDMI/DVI (DP up to 2560x1600@60Hz / HDMI up to 1920x1080@60Hz)
 - 1 x DDI: Embedded DP (up to 2560x1600@60Hz)
- ◆ Ethernet
 - Intel® I210-AT GbE controller (Intel® I210-IT GbE controller with W2 sku)
- ◆ Storage
 - 2 x SATA 3Gb/s signal to baseboard
 - Optional soldered down SSD up to 64 GB (SATA port 1)
- ◆ I/O Interface
 - 4 x USB 2.0 signal to baseboard
 - 1 x USB 3.0 signal to baseboard
- ◆ Audio
 - High-definition Audio interface to baseboard
- ◆ GPIO
 - Yes, to baseboard
- ◆ SMBus
 - Yes, to baseboard
- ◆ I²C
 - Yes, to baseboard
- ◆ LPC
 - Yes, to baseboard
- ◆ SPI
 - Yes, to baseboard
- ◆ Internal Storage
 - 2-Kb serial I²C bus EEPROM supports EAPI Rev. 1.0
- ◆ Serial Port
 - Two serial ports to baseboard (TX & RX from EC)
- ◆ Expansion
 - 3 x PCIe x1 signal to baseboard
- ◆ Watchdog Timer
 - Software programmable, supports 1~255 sec. system reset (from EC)
- ◆ Power Consumption
 - 12V@0.43A, Vcore_12V@0.9 A (Intel® Atom™ E3845 CPU, 2 GB 1333 MHz DDR3L memory)
- ◆ Operating Temperature
 - 20°C ~ 60°C
 - 40°C ~ 85°C (ICE-BT-10-E38001W2)
- ◆ Storage Temperature
 - 20°C ~ 60°C
 - 40°C ~ 85°C (ICE-BT-10-E38001W2)
- ◆ Operating Humidity
 - 5% ~ 95%, non-condensing
- ◆ Dimensions
 - 84 mm x 55 mm (mini size)
- ◆ Weight
 - GW: 300g / NW: 150g

Features

- Intel® 22nm Atom™ on-board SoC supported
- Type 10 connector pinout according to COM.0 R2.1
- Supports 2 GB 1066/1333 MHz DDR3L memory
- Optional soldered down 4 GB SSD
- IEI One Key Recovery solution allows you to create rapid OS backup and recovery
- Support wide range operating temperature: -40°C to +85°C

Dimensions (Unit: mm)

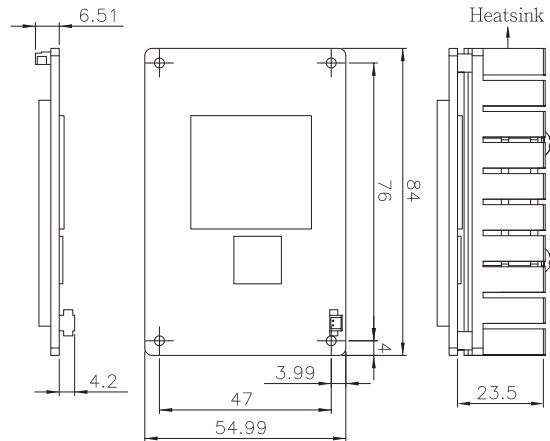

Packing List

| | |
|--------------------------------------|----------------|
| 1 x ICE-BT-T10 single board computer | 1 x QIG |
| 1 x Heatsink | 1 x Utility CD |

Ordering Information

| Part No. | Description |
|-------------------------|--|
| ICE-BT-T10-E38451W2-R10 | COM Express Basic Type 10 module supports Intel® Atom™ processor E3845 (quad core, 10W), on-board 2 GB DDR3L, VGA, DDI, GbE, SATA, USB 3.0 and HD Audio, -40°C ~ 85°C and RoHS |
| ICE-BT-T10-E38251W2-R10 | COM Express Basic Type 10 module supports Intel® Atom™ processor E3825 (dual core, 6W), on-board 2 GB DDR3L, VGA, DDI, GbE, SATA, USB 3.0 and HD Audio, -40°C ~ 85°C and RoHS |
| ICE-BT-T10-E38451-R10 | COM Express Basic Type 10 module supports Intel® Atom™ processor E3845 (quad core, 10W), on-board 2 GB DDR3L, VGA, DDI, GbE, SATA, USB 3.0 and HD Audio, and RoHS |
| ICE-BT-T10-E38251-R10 | COM Express Basic Type 10 module supports Intel® Atom™ processor E3825 (dual core, 6W), on-board 2 GB DDR3L, VGA, DDI, GbE, SATA, USB 3.0 and HD Audio, and RoHS |
| ICE-BT-T10-E38151-R10 | COM Express Basic Type 10 module supports Intel® Atom™ processor E3815 (single core, 5W), on-board 2 GB DDR3L, VGA, DDI, GbE, SATA, USB 3.0 and HD Audio, and RoHS |
| ICE-DB-T10-R10 | Baseboard for COM Express Type 10 module COM.0 Rev. 2.1, supports PICMG EAPI R1.0 |

Note: Models with other CPUs not listed in the table are requested by MOQ - 100 pcs/lot.

1 Industrial Computing Solutions

2 Video Capture Solutions

3 Industrial Computer Chassis

4 Open Frame Monitor

5 Power Supply/ Peripherals

6 All-in-One System

TYPE 6

ICE-BT-T6

COM Express Rev 2.1 Basic Type 6 Module, Intel® 4th Generation Atom™ Processor, VGA, DDI, GbE, SATA 3Gb/s, USB and Audio, RoHS

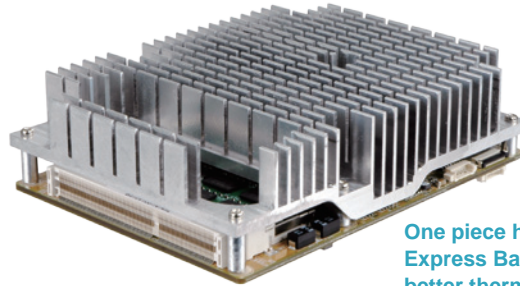
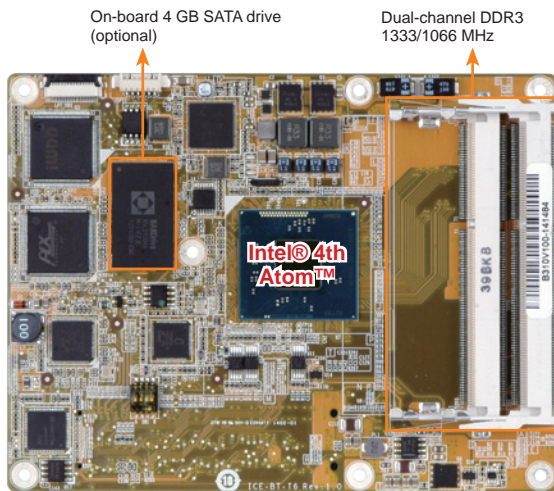

One piece heat sink for COM Express Basic Size provides better thermal solution



Specifications

- ◆ CPU
 - Intel® Atom™ E3845 on-board SoC (1.91GHz, quad-core, 2MB cache, TDP=10W)
 - Intel® Atom™ E3827 on-board SoC (1.75GHz, dual-core, 1MB cache, TDP=8W)
 - Intel® Atom™ E3826 on-board SoC (1.46GHz, dual-core, 1MB cache, TDP=7W)
 - Intel® Atom™ E3825 on-board SoC (1.33GHz, dual-core, 1MB cache, TDP=6W)
 - Intel® Atom™ E3815 on-board SoC (1.46GHz, single-core, 512KB cache, TDP=5W)
 - Intel® Celeron® J1900 on-board SoC (2GHz, quad-core, 2MB cache, TDP=10W)
 - Intel® Celeron® N2930 on-board SoC (1.83GHz, quad-core, 2MB cache, TDP=7.5W)
 - Intel® Celeron® N2807 on-board SoC (1.58GHz, dual-core, 2MB cache, TDP=4.3W)
- ◆ Memory
 - Two 204-pin 1066/1333 MHz dual-channel DDR3L SDRAM unbuffered DIMMs support up to 8 GB
- ◆ BIOS
 - UEFI BIOS
- ◆ Graphics Engine
 - Intel® HD Graphics Gen 7 Engine with 4 execution units, supporting DX11.1, OpenGL 4.2 and OpenCL 1.2
- ◆ Display Output
 - 1 x VGA (up to 2560x1600@60Hz)
 - 1 x DDI 1 (DP up to 2560x1600@60Hz / HDMI up to 1920x1080@60Hz)
 - 1 x LVDS: 18/24-bit dual-channel LVDS (up to 1920x1200@60Hz)
- ◆ Ethernet
 - Intel® I210 GbE Ethernet
- ◆ Storage
 - 2 x SATA 3Gb/s signal to baseboard
 - Optional soldered down SSD up to 64 GB (SATA port 1)
- ◆ Embedded Controller
 - ITE IT8528E/FX
- ◆ USB
 - 7 x USB 2.0 signal to baseboard
 - 4 x USB 3.0 signal to baseboard (via 1 to 4 USB 3.0 hub)
- ◆ Audio
 - High Definition Audio interface to baseboard
- ◆ GPIO
 - Yes, to baseboard
- ◆ SMBus
 - Yes, to baseboard
- ◆ I²C
 - Yes, to baseboard
- ◆ LPC
 - Yes, to baseboard
- ◆ SPI
 - Yes, to baseboard
- ◆ Internal Storage
 - 2-Kb serial I²C bus EEPROM supports EAPI Rev. 1.0
- ◆ Serial Port
 - 2 x Serial ports to baseboard (TX & RX from EC)
- ◆ Expansion
 - 5 x PCIe x1 signal to baseboard (2 from SoC, 3 from PLX PEX8605 switch IC)
- ◆ Watchdog Timer
 - Software programmable, supports 1~255 sec. system reset (by EC)
- ◆ Power Consumption
 - +12V@0.54A, Vcore_12V@0.95A
 - (Intel® Celeron® J1900 CPU with two 8 GB 1333 MHz DDR3 memory)
- ◆ Operating Temperature
 - 20°C ~ 60°C
- ◆ Storage Temperature
 - 30°C ~ 70°C
- ◆ Operating Humidity
 - 5% ~ 95%, non-condensing
- ◆ Dimensions: 125 mm x 95 mm
- ◆ Weight: GW: 600g / NW: 200g



Features

- Intel® 22nm Atom™ or Celeron® on-board SoC supported
- Intel® HD Graphics Gen7 integrates high-performance graphics and media processing
- Supports 1333/1066 MHz DDR3L (1.35V) memory, up to 8 GB
- Supports one analog CRT, one 24-bit dual-channel LVDS, and one DDI
- Optional soldered down 4 GB SSD
- IEI One Key Recovery solution allows you to create rapid OS backup and recovery

Dimensions (Unit: mm)

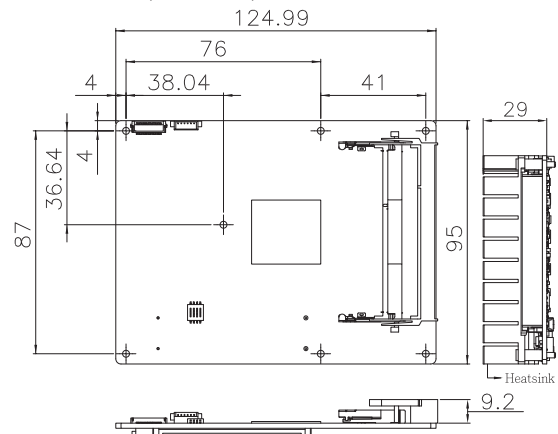

Packing List

| | |
|-------------------------------------|----------------|
| 1 x ICE-BT-T6 single board computer | 1 x Heatsink |
| 1 x QIG | 1 x Utility CD |

Ordering Information

| Part No. | Description |
|----------------------|---|
| ICE-BT-T6-J19001-R10 | COM Express Basic Type 6 module with Intel® Celeron® quad-core processor J1900 (10W), VGA, DDI, LVDS, GbE, SATA, USB 3.0 and HD Audio, RoHS |
| ICE-BT-T6-N29301-R10 | COM Express Basic Type 6 module with Intel® Celeron® quad-core processor N2930 (7.5W), VGA, DDI, LVDS, GbE, SATA, USB 3.0 and HD Audio, RoHS |
| ICE-BT-T6-N28071-R10 | COM Express Basic Type 6 module with Intel® Celeron® dual-core processor N2807 (4.3W), VGA, DDI, LVDS, GbE, SATA, USB 3.0 and HD Audio, RoHS |
| ICE-BT-T6-E38XX1-R10 | COM Express Basic Type 6 module with Intel® Atom™ processor E38XX, VGA, DDI, LVDS, GbE, SATA, USB 3.0 and HD Audio, RoHS (by request MOQ: 100pcs/lot) |
| ICE-DB-T6R-R11 | Baseboard for COM Express Type 6 Module COM.0 Rev. 2.1, supports PICMG EAPI R1.0 |
| 19100-000186-00-RS | Heat spreader for ICE-BT-T6 |

1
Industrial
Computing
Solutions

2
Video
Capture
Solutions

3
Industrial
Computer
Chassis

4
Open
Frame
Monitor

5
Power Supply/
Peripherals

6
All-in-One
System



ICE-QM871

COM Express Basic Type 6 Module Supports Intel® 22nm 4th Generation Mobile Core™ Processor, VGA, LVDS, DDI, GbE, PCIe Gen3, SATA 6Gb/s, USB 3.0 and HD Audio, RoHS

Dual-channel DDR3 1333/1066 MHz

Com Express Rev 2.1 Type 6 Pinout

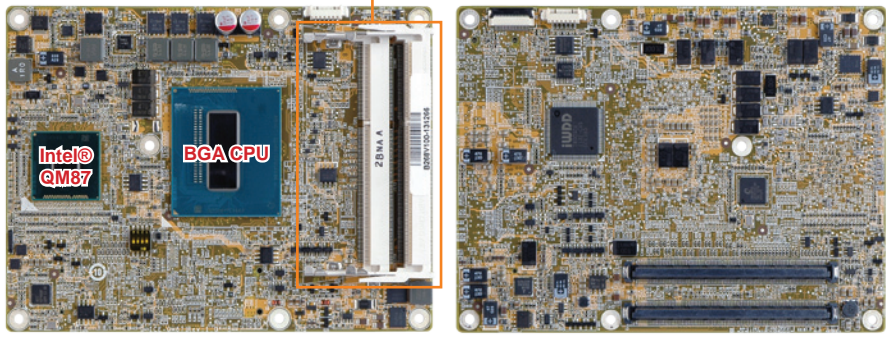

| | | | | | | | | | |
|---|-----------------|------------------|-------|-----------------|-----------------|----------|--------|------|--------------------|
| D | 4 ports USB 3.0 | 2 lanes PCIe x 1 | DDI 1 | DDI 2 | DDI 3 | PCIe x16 | 12V | | |
| B | LPC SMB PC | 4 ports SATA | Audio | 8 ports USB 2.0 | 6 lanes PCIe x1 | LVDS B | VGA | 5VSB | 12V |
| A | GBE | | | | | LVDS A | Others | SPI | 2 ports serial 12V |

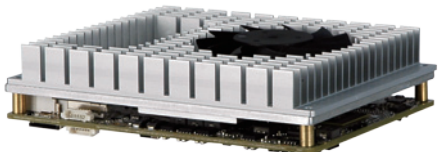

Addition mounting holes for better contact with heatspreader

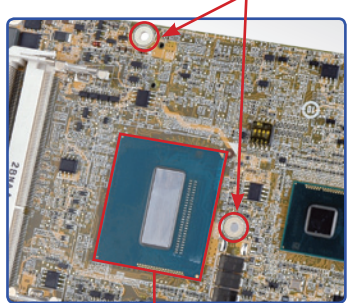

4th Generation Intel® Core™ BGA CPU



Specifications

- ◆ CPU
 - Intel® mobile Core™ i7-4700EQ on-board processor with Intel® AMT 9.0 support (2.4GHz, quad-core, 6MB cache, TDP=47W)
 - Intel® mobile Core™ i5-4402E on-board processor with Intel® AMT 9.0 support (1.6GHz, dual-core, 3MB cache, TDP=25W)
 - Intel® mobile Core™ i3-4102E on-board processor (1.6GHz, dual-core, 3MB cache, TDP=25W)
 - Intel® mobile Celeron® 2002E on-board processor (1.5GHz, dual-core, 2MB cache, TDP=25W)
 - Intel® mobile Core™ i5-4400E on-board processor with Intel® AMT 9.0 support (2.7GHz, dual-core, 3MB cache, TDP=37W) (by request)
 - Intel® mobile Core™ i3-4100E on-board processor (2.4GHz, dual-core, 3MB cache, TDP=37W) (by request)
 - Intel® mobile Celeron® 2000E on-board processor (2.2GHz, dual-core, 2MB cache, TDP=37W)(by request)
- ◆ System Chipset
 - Intel® QM87
- ◆ Memory
 - Two 204-pin 1600/1333 MHz dual-channel DDR3 & DDR3L SDRAM unbuffered DIMMs support up to 16 GB
- ◆ BIOS
 - UEFI BIOS
- ◆ Graphics Engine
 - Intel® HD Graphics Gen 7.5 supports DX11.1 and OpenCL 1.2, OpenGL 3.2
 - Full MPEG2, VC1, AVC Decode
- ◆ Display Output
 - 3 x DDI: DisplayPort/HDMI/DVI (up to 2560x1600@60 Hz)
 - 1 x VGA (up to 1920x1200@60 Hz)
 - 1 x Dual-channel 18/24-bit LVDS (up to 1920x1200@60 Hz)
- ◆ Ethernet
 - LAN: Intel® I217LM Clarkville-V with Intel® AMT 9.0 support
- ◆ I/O Interface
 - 2 x RS-232 (to baseboard) 4 x SATA 6Gb/s signal (to baseboard)
 - 8 x USB 2.0 (to baseboard) 4 x USB 3.0 (to baseboard)
- ◆ Audio
 - High Definition Audio interface
- ◆ SMBus
 - Yes (to baseboard)
- ◆ PC
 - Yes (to baseboard)
- ◆ LPC
 - Yes (to baseboard)
- ◆ Expansion
 - 1 x PCIe x16 signal (to baseboard)
 - 7 x PCIe x1 signal (to baseboard)
- ◆ Watchdog Timer
 - Software programmable, support 1~255 sec. system reset
- ◆ GPIO
 - 8-bit GPIO
- ◆ Power Consumption
 - +12V1@1.86A, +12V2@3.70A
 - (Intel® Core™ i7-4700EQ 2.4GHz CPU with 8 GB (two 4 GB) 1333 MHz DDR3 memory)
- ◆ Operating Temperature
 - 20°C ~ 60°C
- ◆ Storage Temperature
 - 30°C ~ 70°C
- ◆ Operating Humidity
 - 5% ~ 95%, non-condensing
- ◆ Dimensions
 - 125mm x 95mm
- ◆ Weight
 - GW: 600g / NW: 250g

Features

- 4th generation Intel® mobile Core™ i7/i5/i3 or Celeron® on-board processor
- Intel® HD Graphics technology integrates high-performance graphics and media processing
- Dual-channel 1600/1333 MHz DDR3 support up to 16 GB
- Support 1.5V/1.35V DDR3 SO-DIMM
- 18/24-bit dual-channel LVDS, analog CRT and three DDI supported
- IEI One Key Recovery solution allows you to create rapid OS backup and recovery
- Support AMT 9.0

Packing List

| |
|-------------------------------------|
| 1 x ICE-QM871 single board computer |
| 1 x Heatspreader |
| 1 x Utility CD |
| 1 x Cooler |
| 1 x Driver CD |
| 1 x QIG |

Ordering Information

| Part No. | Description |
|-------------------|---|
| ICE-QM871-i7-R10 | COM Express Basic Type 6 module supports Intel® 22nm 4th Generation Mobile Core™ i7-4700EQ processor (47W), VGA, LVDS, DDI, GbE, PCIe Gen3, AMT 9.0, SATA 6Gb/s, USB 3.0 and HD Audio, RoHS |
| ICE-QM871-i5E-R10 | COM Express Basic Type 6 module supports Intel® 22nm 4th Generation Mobile Core™ i5-4402E processor (25W), VGA, LVDS, DDI, GbE, PCIe Gen3, AMT 9.0, SATA 6Gb/s, USB 3.0 and HD Audio, RoHS |
| ICE-QM871-i3E-R10 | COM Express Basic Type 6 module supports Intel® 22nm 4th Generation Mobile Core™ i3-4102E processor (25W), VGA, LVDS, DDI, GbE, PCIe Gen3, SATA 6Gb/s, USB 3.0 and HD Audio, RoHS |
| ICE-QM871-CE-R10 | COM Express Basic Type 6 module supports Intel® 22nm 4th Generation Celeron® Mobile 2002E processor (25W), VGA, LVDS, DDI, GbE, PCIe Gen3, SATA 6Gb/s, USB 3.0 and HD Audio, RoHS |
| ICE-DB-T6R-R11 | Base Board for COM Express Type 6 Module COM.0 Rev. 2.1, support PICMG EAPI R1.0 |

- Industrial Computing Solutions
- Video Capture Solutions
- Industrial Computer Chassis
- Open Frame Monitor
- Power Supply/ Peripherals
- All-in-One System

TYPE 6

ICE-QM770

COM Express Basic Type 6 Module with Socket G2 Supports Intel® 2nd & 3rd Generation Core™ i7/i5/i3 Celeron® Processor, VGA/LVDS, DDI, GbE, SATA 6Gb/s, USB 3.0, Audio and RoHS

Dual-channel DDR3 1333/1066 MHz

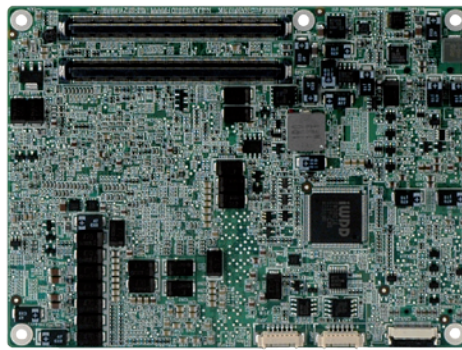
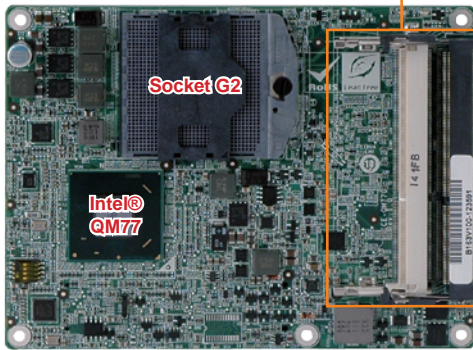

Three DDI (Digital Display Interface) by carrier board

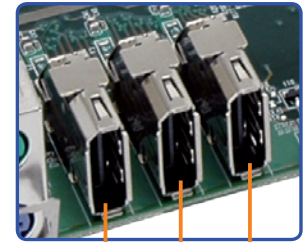

Specifications

- ◆ Form Factor
PICMG COM Express R2.0 Basic Type 6
- ◆ CPU
Socket G2 for 2nd & 3rd generation Intel® Core™ i7/i5/i3/Pentium®/Celeron® processor
- ◆ PCH
Intel® QM77
- ◆ Memory
Two 204-pin 1600/1333MHz dual-channel unbuffered DDR3 SDRAM SO-DIMMs support up to 16GB
Supports 1.35V DDR3L
- ◆ BIOS
UEFI BIOS
- ◆ Graphics Engine
Intel® HD Graphics 2000/3000
Supports DX11, OCL 1.1 and OpenGL 3.0
Full MPEG2, VC1, AVC Decode
- ◆ Display Output
3 x DDI (up to 2560x1600@60Hz)
1 x VGA up to QXGA (up to 2048x1536@75Hz)
1 x 18/24-bit dual-channel LVDS up to UXGA (up to 1920x1200@60Hz)
- ◆ Ethernet
Intel® 82579LM
- ◆ Embedded Controller
iWDD
- ◆ I/O Interface
2 x RS-232 (to baseboard) (3.3V) 8 x USB 2.0 (to baseboard)
4 x USB 3.0 (to baseboard) 2 x SATA 3Gb/s (signal to baseboard)
2 x SATA 6Gb/s (signal to baseboard)
- ◆ Audio
High Definition Audio
- ◆ SMBus
Yes (to baseboard)
- ◆ I²C
Yes (to baseboard)
- ◆ LPC
Yes (to baseboard)
- ◆ Expansion
1 x PCIe x16 signal (to baseboard)
7 x PCIe x1 signal (to baseboard)
- ◆ Watchdog Timer
Software programmable supports 1~255 sec. system reset
- ◆ GPIO
8-bit GPIO (to baseboard)
- ◆ TPM
Through the baseboard
- ◆ Intel® AMT
Supports Intel® AMT 8.0
- ◆ Power Consumption
+12V@1.75A, Vcore_12V@3.33A (Intel® 1.8GHz CPU with 4 GB 1333 MHz DDR3 memory)
- ◆ Operating Temperature
-10°C ~ 60°C
- ◆ Storage Temperature
-20°C ~ 70°C
- ◆ Operating Humidity
5% ~ 95%, non-condensing
- ◆ Dimensions
338 mm x 126 mm
- ◆ Weight
GW: 700g / NW: 250g



2nd & 3rd generation Intel® Core™ processors supported



Features

- Intel® Core™ i7/i5/i3/Celeron® processors supported
- Intel® HD Graphics technology integrates high-performance graphics and media processing
- 1600/1333/1066 MHz dual-channel DDR3 memory supports up to 16 GB
- Supports 1.35V DDR3L
- 18/24-bit dual-channel LVDS, analog CRT and three DDI supported
- IEI One Key Recovery solution allows you to create rapid OS backup and recovery

Dimensions (Unit: mm)

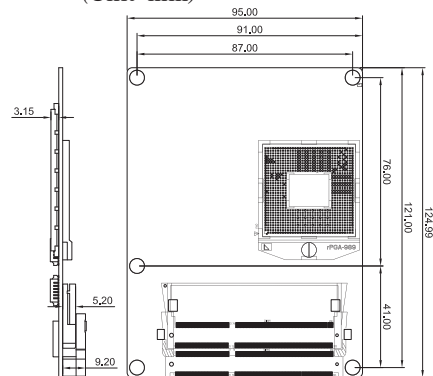

Packing List

| | |
|---|----------------|
| 1 x ICE-QM770-R10 single board computer | |
| 1 x Heatspreader for Socket G2 CPU (22nm) | |
| 1 x Cooler | 1 x Utility CD |
| 1 x Driver CD | 1 x QIG |

Ordering Information

| Part No. | Description |
|---------------|--|
| ICE-QM770-R10 | COM Express Basic Type 6 Module with Socket G2 Supports Intel® 2nd & 3rd Generation Core™ i7/i5/i3 Celeron® Processor, VGA/LVDS, DDI, GbE, SATA 6Gb/s, USB 3.0, Audio and RoHS |
| ICE-DB-T6-R10 | Baseboard for COM Express Type 6 modules |

1 Industrial Computing Solutions
2 Video Capture Solutions
3 Industrial Computer Chassis
4 Open Frame Monitor
5 Power Supply/Peripherals
6 All-in-One System

TYPE 10

ICE-DB-T10

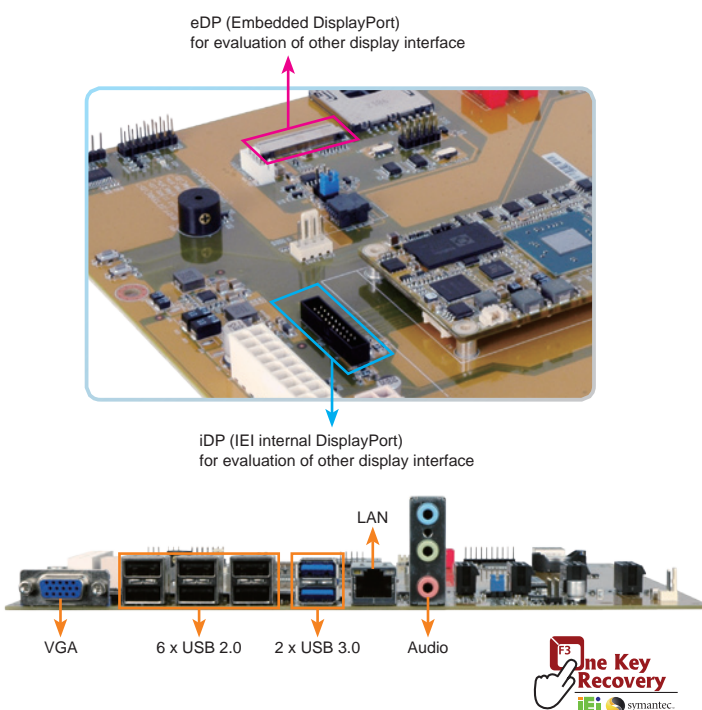
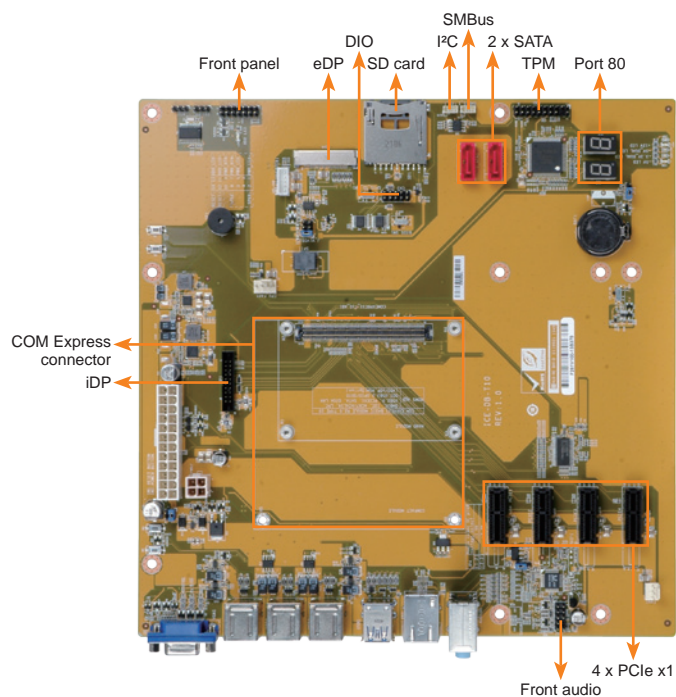
Baseboard for COM Express Type 10 Module COM.0 Rev. 2.1, support PICMG EAPI R1.0

Specifications

- ◆ Form Factor
microATX form factor baseboard (244mm x 244mm)
- ◆ COM Express type
Supports COM Express Compact/Mini module using connector pin out Type 10
- ◆ Display Interfaces
1 x eDP
1 x VGA
1 x DisplayPort pin-header
- ◆ Audio
Realtek ALC662 HD Audio codec (Line-in, Line-out, Mic)
- ◆ Internal I/O Interface
4 x PCIe x1 1 x LPC
2 x SATA port 1 x SD card socket
2 x RS-232 from COM Express (only TX, RX, GND)
- ◆ External I/O Interface
1 x VGA 1 x Audio jack (Line-in, Line-out, Mic)
2 x USB 3.0 6 x USB 2.0
1 x RJ-45
- ◆ Front Audio
1 x Front audio (2x5 pin)
- ◆ TPM
1 x TPM connector (2x10 pin)
- ◆ 80 Port
1 x 80 port (2x7 segment display)
- ◆ Front Panel
1 x Front panel (2x7 pin, power LED, HDD LED, speaker(Buzzer), power button, reset button)
- ◆ I2C
1 x I2C (1x4 pin)
- ◆ SMBus
1 x SMBus (1x4 pin)
- ◆ Internal Storage
EEPROM (support EAPI R1.0)
- ◆ LPC
1 x LPC
- ◆ Fan Connector
1 x 4-pin / 1 x 3 pin CPU module fan connector
- ◆ Watchdog Timer
Software programmable, support 1~255 sec. system reset
- ◆ Power Supply
ATX / AT power supply
24+4 pin
- ◆ Operating Temperature
-20°C ~ 60°C
- ◆ Storage Temperature
-30°C ~ 70°C
- ◆ Operating Humidity
5% ~ 95%, non-condensing
- ◆ Dimensions
243.8 mm x 243.8 mm (9.6" x 9.6")



Features

- mATX form factor baseboard for COM.0 Rev. 2.1, Pin-out Type 10
- Support four PCIe x1
- Support eDP, VGA and iDP
- Support PICMG EAPI R1.0

Dimensions (Unit: mm)

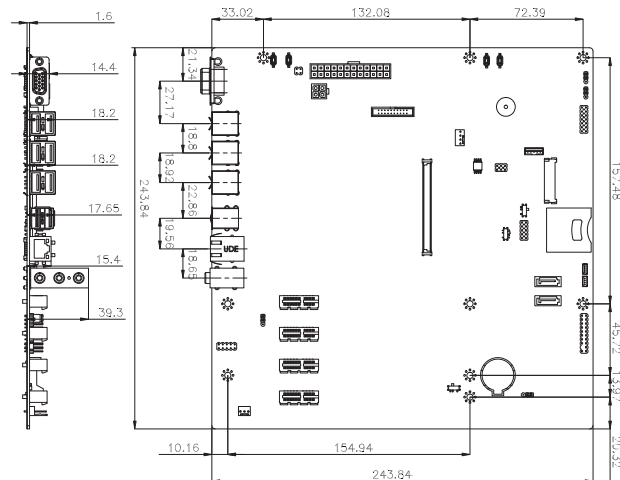

Packing List

| | |
|---------------------------|----------------|
| 1 x COM Express Baseboard | 1 x SATA cable |
| 1 x Mini jumper pack | 1 x QIG |

Ordering Information

| Part No. | Description |
|---------------------|--|
| ICE-DB-T10-R10 | Baseboard for COM Express Type 10 Module COM.0 Rev. 2.1, support PICMG EAPI R1.0 |
| 19800-000082-RS | RS-232/422/485 cable, 14-pin to dual DB-9, 230mm, P=2.54 |
| 32102-000100-200-RS | SATA power cable, MOLEX 5264-4P to SATA15P |

1

Industrial
Computing
Solutions

2

Video
Capture
Solutions

3

Industrial
Computer
Chassis

4

Open
Frame
Monitor

5

Power Supply/
Peripherals

6

All-in-One
System

TYPE 6

ICE-DB-T6R

Baseboard for COM Express Type 6 Module COM.0 Rev. 2.1
(for ICE-ULT3, ICE-QM871 & ICE-BT-T6)

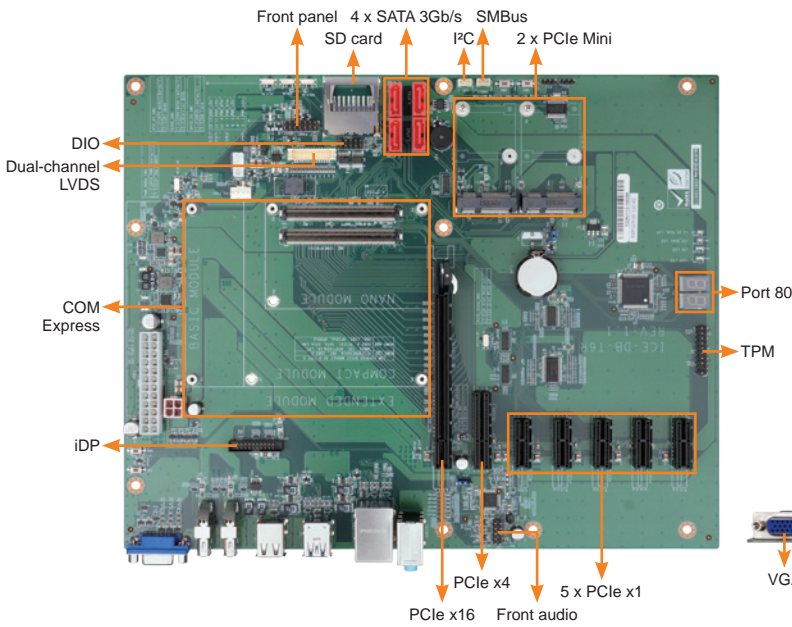

IEI iDP for evaluation of other display interface

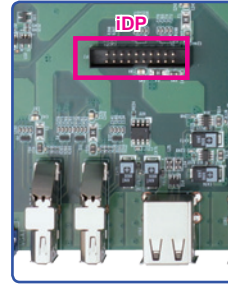

Three Sizes and Two Type (Type 6 & Type 10) compatible

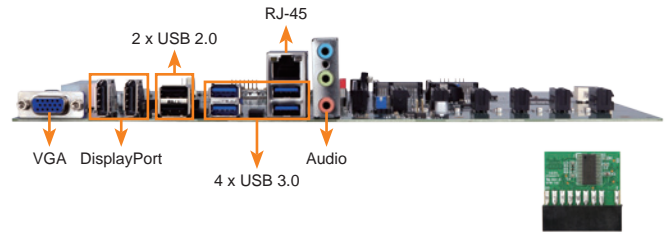
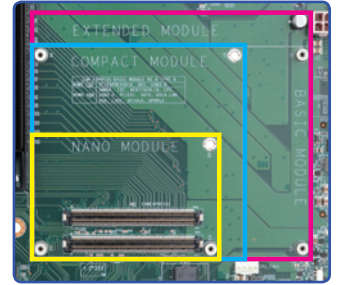

TPM 1.2 Support

Specifications

- ◆ Form Factor
 - ATX form factor baseboard
- ◆ CPU
 - Supports COM Express Compact/Mini module using connector pin out Type 6
- ◆ Display Interfaces
 - 1 x DisplayPort connectors
 - 1 x LVDS 18/24-bit single or dual-channel (with PWM back light controller)
 - 1 x VGA
 - 2 x DisplayPort pin-header
- ◆ Audio
 - Realtek ALC662 HD Audio codec (Line-in, Line-out, Mic)
- ◆ Expansion
 - 1 x LPC
 - 1 x PCIe x4
 - 1 x PCIe x16
 - 5 x PCIe x1
 - 2 x PCIe Mini (MINIPICIE1 with mSATA support, colay with SATA_4)
- ◆ Internal I/O Interface
 - 1 x PS2 KB/MS
 - 4 x SATA port
 - 1 x SD card socket
- ◆ External I/O Interface
 - 1 x Audio jack (Line-in, Line-out, Mic)
 - 1 x RJ-45
 - 1 x DisplayPort connectors
 - 1 x VGA
 - 1 x HDMI
 - 2 x USB 2.0
 - 1 x PS2 KB/MS
 - 4 x USB 3.0
- ◆ Front Audio
 - 2 x 5-pin pin header
- ◆ TPM
 - 1 x TPM (2x10 pin)
- ◆ 80 port
 - 2 x 7 segment display
- ◆ Front Panel
 - 1 x Front panel (2x7 pin, power LED, HDD LED, speaker/buzzer, power button, reset button)
- ◆ I²C
 - 1 x 4-pin wafer
- ◆ SMBus
 - 1 x 4-pin wafer
- ◆ Internal storage
 - EEPROM (supports EAPI R1.0)
- ◆ Watchdog Timer
 - Software programmable supports 1~255 sec system reset
- ◆ GPIO
 - 8-bit GPIO
- ◆ Power Supply
 - ATX / AT Power Supply
 - 24+4 pins
- ◆ Fan Connector
 - 1 x 4-pin / 1 x 3-pin CPU module fan connector
 - 1 x 3-pin system fan connector by SIO
- ◆ Operating Temperature
 - 20°C ~ 60°C
- ◆ Storage Temperature
 - 30°C ~ 70°C
- ◆ Operating Humidity
 - 5% ~ 95 non-condensing
- ◆ Dimensions
 - 304.8 mm x 243.8 mm (12" x 9.6")



Features

- ATX form factor baseboard for COM.0 Rev. 2.1, pin-out Type 6
- Support one PCIe x16, one PCIe x4, five PCIe x1, two PCIe Mini
- Support PICMG EAPI R1.0

Dimensions (Unit: mm)

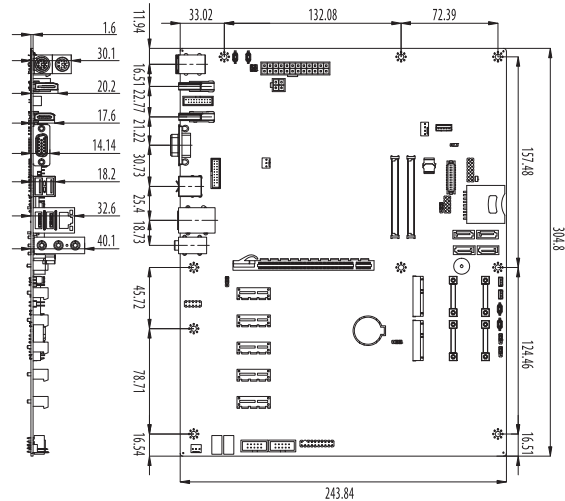

Packing List

| | |
|---------------------------|----------------------|
| 1 x COM Express baseboard | 1 x Mini jumper pack |
| 2 x SATA cable | 1 x QIG |

Ordering Information

| Part No. | Description |
|---------------------|---|
| ICE-DB-T6R-R11 | Baseboard for COM Express Type 6 Module COM.0 Rev. 2.1, support PICMG EAPI R1.0 |
| 32102-000100-200-RS | SATA power cable, MOLEX 5264-4P to SATA15P |

1 Industrial Computing Solutions
2 Video Capture Solutions
3 Industrial Computer Chassis
4 Open Frame Monitor
5 Power Supply/Peripherals
6 All-in-One System

TYPE 6

ICE-DB-T6

Baseboard for COM Express Type 6 Module
(for ICE-QM770 & ICE-CV-D25501/N26001)

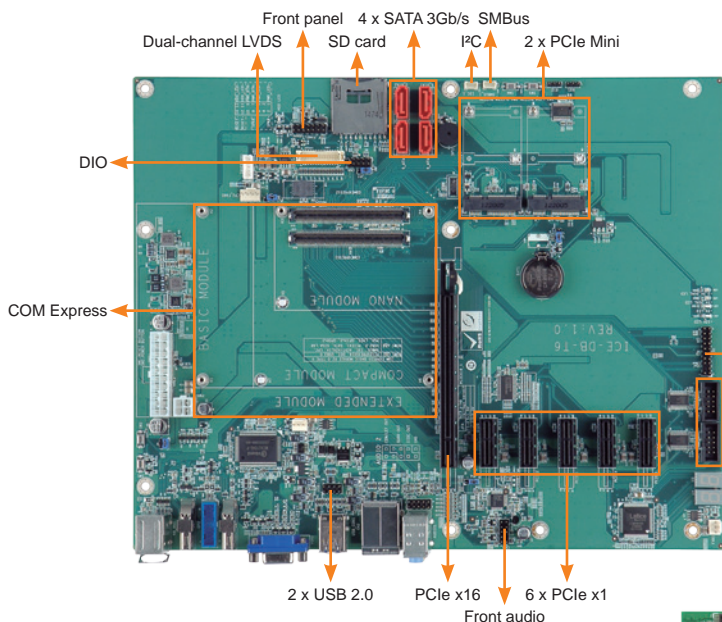

Three DisplayPort for Three DDI



Three Sizes and Two Types (Type 6 & Type 10) Compatible

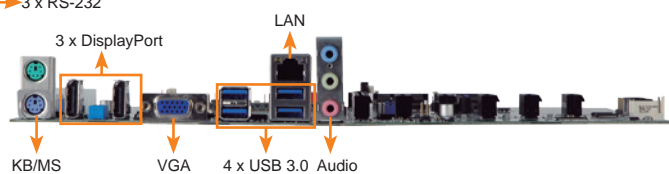
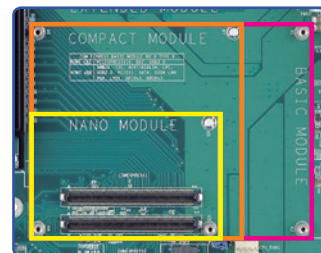

Specifications

- ◆ Form Factor
ATX form factor baseboard
- ◆ CPU
Supports COM Express Compact/Mini module using connector pin out Type 6
- ◆ Display Interfaces
1 x 18/24-bit single/dual-channel LVDS
1 x VGA
3 x DisplayPort (2 x real connectors, 1 x pin header)
- ◆ Super I/O
W83627DHG
- ◆ Audio
Realtek ALC892 HD Audio codec (Line-in, Line-out, Mic)
- ◆ Expansion
1 x PCIe x16 6 x PCIe x1
2 x PCIe Mini (with USB) 1 x LPC
- ◆ Internal I/O Interface
4 x SATA port 2 x RS-232 from COM Express (only TX, RX and GND)
2 x RS-232 from SIO 1 x PS2 KB/MS
2 x USB 2.0 1 x SD
- ◆ External I/O Interface
1 x VGA 4 x USB 3.0
1 x RJ-45 3 x DisplayPort
1 x Audio jack (Line-in, Line-out, Mic)
- ◆ Front Audio
1 x Front audio (2x5 pin)
- ◆ TPM
1 x TPM (2x10 pin)
- ◆ 80 port
2 x 7 segment display
- ◆ Front Panel
1 x Front panel (2x7 pin, power LED, HDD LED, speaker/buzzer, power button, reset button)
- ◆ I²C
1 x 4-pin wafer
- ◆ SMBus
1 x 4-pin wafer
- ◆ Watchdog Timer
Software programmable supports 1~255 sec. system reset
- ◆ GPIO
8-bit GPIO (GPIO from iWDD co-layer SDIO)
- ◆ Power Supply
ATX/AT power supply
- ◆ Battery
Supports smart battery charger connector
- ◆ Fan Connector
1 x 4-pin / 1 x 3-pin CPU module fan connector
1 x 3-pin system fan connector by SIO
- ◆ Operating Temperature
-10°C ~ 60°C
- ◆ Storage Temperature
-20°C ~ 70°C
- ◆ Operating Humidity
5% ~ 95%, non-condensing
- ◆ Dimensions
304.8 mm x 243.8 mm (12" x 9.6")

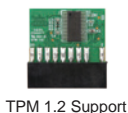

Features

- ATX form factor baseboard for COM Express Rev. 2, Pin-out Type 6
- Supports one PCIe x16, six PCIe x1 and two PCIe Mini
- Supports smart battery charger

Dimensions (Unit: mm)

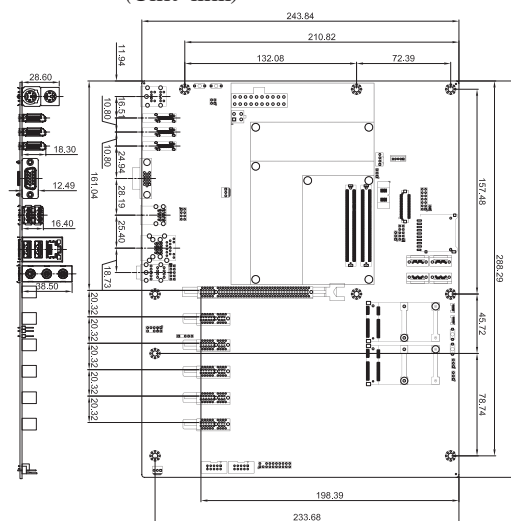

Packing List

| | |
|----------------------------|----------------------|
| 1 x COM Express baseboard | |
| 1 x Dual-port RS-232 cable | 1 x Mini jumper pack |
| 2 x SATA cable | 1 x Utility CD |
| 1 x One Key Recovery CD | 1 x QIG |

Ordering Information

| Part No. | Description |
|---------------------|--|
| ICE-DB-T6-R10 | Baseboard for COM Express Type 6 modules |
| 19800-000082-RS | RS-232/422/485 cable, 14-pin to dual DB-9, 230mm, P=2.54 |
| 32102-000100-200-RS | SATA power cable, MOLEX 5264-4P to SATA15P |

- 1 Industrial Computing Solutions
- 2 Video Capture Solutions
- 3 Industrial Computer Chassis
- 4 Open Frame Monitor
- 5 Power Supply/Peripherals
- 6 All-in-One System

Q7 Introduction

- The Qseven™ concept is an off-the-shelf, multi vendor, Single Board Computer that integrates all the core components of a common PC and is mounted onto an application specific carrier board.
- Qseven™ modules have a standardized form factor of 70mm x 70mm and have specified pinouts based on the high speed MXM system connector that has a standardized pinout regardless of the vendor.
- The Qseven™ module provides the functional requirements for an embedded application. These functions include, but are not limited to, graphics, sound, mass storage, network and multiple USB ports. A singleruggedized MXM connector provides the carrier board interface to carry all the I/O signals to and from the Qseven™ module.

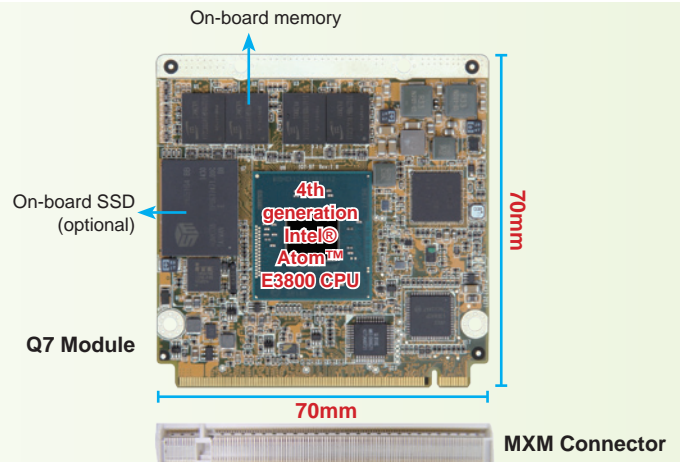

The New Module Standard

Compact, Square & Cost Efficient
Module Concept for Ultra Mobile Applications

- Low Cost
- Low Power Consumption
- Legacy Free
- Fast Serial Interfaces

ETX, COM Express and Q7 Comparison Table

| Platform | ETX 3.0 | COM Express Type II Basic Module | Q7 |
|------------------|-------------------------|--|-----------------------|
| Size | 95 x 114 mm | 95 x 125 mm | 70 x 70 mm |
| Connector | 4 x 100-pin | 2 x 220-pin | 1 x 230-pin |
| Memory | 1 x SO-DIMM | 1 x SO-DIMM | on board memory |
| VGA | Yes | Yes | N/A |
| LCD | TTL or LVDS | Up to two single LVDS or Dual-channel LVDS | SDVO/HDMI/DP (Shared) |
| Expansion | PCI & ISA | PCI & PCI Express | PCI Express |
| Ethernet | 10/100 Mbps | 10/100/1000 Mbps | 10/100/1000Mbps |
| USB | 4 | 8 | 8 |
| SATA | 2 (ETX 3.0 only) | Up to 4 SATA | Up to 2 SATA |
| IDE | 2CH | 1CH | N/A |
| Audio | Mic-In/Line-in/Line-Out | AC97/HD interface | HD interface |
| Power | 5V | 12V | 5V |

Defined Interfaces

- 4 x PCI Express x1 Lanes
- 2 x SATA
- 8 x USB 2.0
- 1 x 1000BaseT Ethernet
- 1 x SDIO 8 bit
- 2 x 24-bit LVDS
- SDVO / HDMI / DisplayPort (shared)
- HDA (High Definition Audio)
- I²C Bus
- LPC (Low Pin Count Bus)
- CAN Bus
- Fan Control
- Power Management Signals
- Battery Management
- 5V Power (TDP 12 Watt)
- Unique API for I²C Bus, Watchdog Timer and EPI (Embedded Panel Interface)
- Thermal Cooling Interface defined

Typical Applications



Automation Controllers



Mobile Devices



Measurement Systems

1

Industrial Computing Solutions

2

Video Capture Solutions

3

Industrial Computer Chassis

4

Open Frame Monitor

5

Power Supply/Peripherals

6

All-in-One System

iQ7-AL ALW2

Qseven® Rev. 2.0 module supports Intel® 6th Generation Atom™/Celeron® Processor, LVDS/eDP, DisplayPort, GbE, SATA 6Gb/s, USB 3.0, Audio and RoHS, -40°C~85°C



On-board eMMC (optional)
solder-down 1333/1600 MHz DDR3L

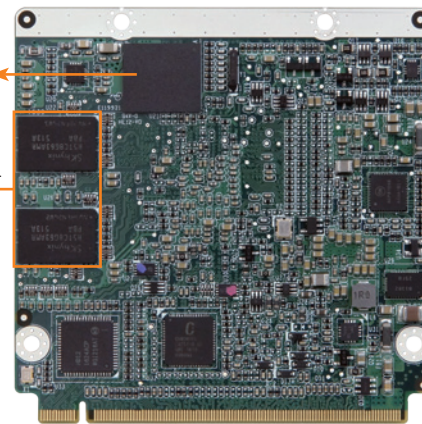

Preliminary

Bottom side

Specifications

- ◆ CPU
 - Intel® Atom™ E3950 on-board SoC (up to 2.0GHz, quad-core, 2M Cache, TDP=12W)
 - Intel® Atom™ E3940 on-board SoC (up to 1.8GHz, quad-core, 2M Cache, TDP=9W)
 - Intel® Atom™ E3930 on-board SoC (up to 1.8GHz, dual-core, 2M Cache, TDP=6W)
 - Intel® Pentium® N4200 on-board SoC (up to 2.5GHz, quad-core, 2M Cache, TDP=6W)
 - Intel® Celeron® N3350 on-board SoC (up to 2.4GHz, dual-core, 2M Cache, TDP=6W)
- ◆ Memory
 - 4 GB solder-down 1333/1600 MHz DDR3L memory (for E3950, E3940)
 - 2 GB solder-down 1333/1600 MHz DDR3L memory (for E3930)
- ◆ BIOS
 - UEFI BIOS
- ◆ Graphics Engine
 - Intel® HD Graphics Gen9 Low Power, 18 Execution Units
 - 4K Codec Decode & Encode for HEVC 4, H.264, VP8, SVC, MVC
- ◆ Display Output
 - 1 x 18/24-bit dual-channel LVDS (up to 1920x1200@60Hz)
 - 1 x eDP/LVDS-A channel (optional)
 - 1 x DDI (DP/HDMI up to 3840x2160@30Hz)
- ◆ Ethernet
 - Intel® I210 GbE Ethernet
- ◆ Embedded Controller
 - ITE IT8528E/FX
- ◆ Storage
 - Optional soldered down 8GB eMMC 5.0
 - 2 x SATA 6Gb/s signal to baseboard
- ◆ USB 2.0
 - 6 x USB 2.0 signal to base board
- ◆ USB 3.0
 - 1 x USB 3.0 signal to base board
- ◆ Audio
 - High definition audio interface to baseboard
- ◆ GPIO
 - YES, to baseboard
- ◆ SMBus
 - YES, to baseboard
- ◆ I²C
 - I²C x3, to baseboard
- ◆ LPC
 - YES, to baseboard
- ◆ SDIO
 - 8-bit SDIO 3.0 x 4, to baseboard
- ◆ SPI
 - YES, to baseboard
- ◆ I2S
 - YES, to baseboard
- ◆ Serial port
 - 2 serial ports to base board (TX & RX form EC)
- ◆ Expansion
 - 4 x PCIe x1 signal to baseboard (3 PCIe x1 or 2 PCIe x1 + 1 PCIe x2)
- ◆ Watchdog Timer
 - Software programmable support 1~255 sec. system reset (form EC)
- ◆ Power Consumption
 - TBD
- ◆ Operating Temperature
 - 20°C ~ 60°C
 - 40°C ~ 85°C (iQ7-AL-ExW2)
- ◆ Storage Temperature
 - 40°C ~ 85°C
- ◆ Operating Humidity
 - 5% ~ 95%, non-condensing
- ◆ Dimensions
 - 70 mm x 70 mm
- ◆ Weight
 - GW: 300g / NW: 150g



Features

- Intel® 14nm Atom™ or Celeron® on-board SoC supported
- Qseven® connector pinout according to Qseven® Specification Revision 2.0
- Optional eMMC 5.0 soldered down up to 64GB
- Support -40°C ~ 85°C

Packing List

| | |
|----------------------------------|----------------|
| 1 x iQ7-AL single board computer | 1 x QIG |
| 1 x Heatsink | 1 x Utility CD |

Ordering Information

| Part No. | Description |
|-------------------|---|
| iQ7-AL-E1-R10 | Qseven® Rev. 2.0 module supports Intel® Atom™ Dual-core processor E3930 (5.5W), 2GB DDR3L LVDS, DDI, GbE, USB 3.0, SATA 3Gb/s, Audio, -20°C~70°C and RoHS |
| iQ7-AL-E2-R10 | Qseven® Rev. 2.0 module supports Intel® Atom™ Quad-core processor E3940 (9W), 4GB DDR3L LVDS, DDI, GbE, USB 3.0, SATA 3Gb/s, Audio, -20°C~70°C and RoHS |
| iQ7-AL-E3-R10** | Qseven® Rev. 2.0 module supports Intel® Atom™ Quad-core processor E3950 (13W), 4GB DDR3L LVDS, DDI, GbE, USB 3.0, SATA 3Gb/s, Audio, -20°C~70°C and RoHS |
| iQ7-AL-E1W2-R10** | Qseven® Rev. 2.0 module supports Intel® Atom™ Dual-core processor E3930 (5.5W), 2GB DDR3L LVDS, DDI, GbE, USB 3.0, SATA 3Gb/s, Audio, -40°C~85°C and RoHS |
| iQ7-AL-E2W2-R10** | Qseven® Rev. 2.0 module supports Intel® Atom™ Quad-core processor E3940 (9W), 4GB DDR3L LVDS, DDI, GbE, USB 3.0, SATA 3Gb/s, Audio, -40°C~85°C and RoHS |
| iQ7-AL-E3W2-R10** | Qseven® Rev. 2.0 module supports Intel® Atom™ Quad-core processor E3950 (13W), 4GB DDR3L LVDS, DDI, GbE, USB 3.0, SATA 3Gb/s, Audio, -40°C~85°C and RoHS |
| iQ7-AL-N1-R10** | Qseven® Rev. 2.0 module supports Intel® Celeron® Dual-Core Processor N3350(6W), 2GB DDR3L LVDS, DDI, GbE, SATA 3Gb/s, USB 3.0, Audio, -20°C~70°C and RoHS |
| iQ7-AL-N2-R10** | Qseven® Rev. 2.0 module supports Intel® Celeron® Quad-Core Processor N4200(6W), 4GB DDR3L LVDS, DDI, GbE, SATA 3Gb/s, USB 3.0, Audio, -20°C~70°C and RoHS |
| iQ7-DB-MATX2-R10 | Base Board for Qseven® Rev. 2.0 module |

**By order production, MOQ: 100

1

Industrial Computing Solutions

2

Video Capture Solutions

3

Industrial Computer Chassis

4

Open Frame Monitor

5

Power Supply/ Peripherals

6

All-in-One System

iQ7-BTW2/iQ7-BT

Qseven Rev. 2.0 Module Supports 4th generation Intel® Atom™ Processor, LVDS, DDI, GbE, SATA 3Gb/s, USB 3.0, SDIO, Audio, -40°C~85°C and RoHS

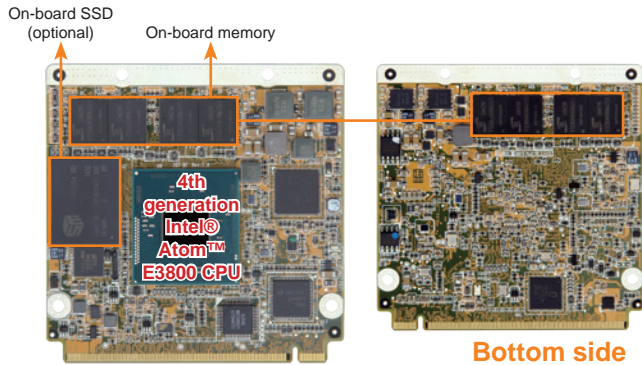

Features

- 22nm Intel® Atom™ on-board SoC supported
- Qseven connector pinout according to Qseven Specification Revision 2.0
- Supports 2 GB 1066/1333 MHz DDR3L memory (4 GB optional)
- Optional soldered-down 2 GB~64 GB SSD
- IEI One Key Recovery solution allows you to create rapid OS backup and recovery

Specifications

- ◆ CPU
 - Intel® Atom™ E3845 on-board SoC (1.91GHz, quad-core, 2MB cache, TDP=10W)
 - Intel® Atom™ E3825 on-board SoC (1.33GHz, dual-core, 1MB cache, TDP=6W)
- ◆ Memory
 - 2 GB soldered-down 1066/1333 MHz DDR3L memory (up to 4 GB)
- ◆ BIOS: UEFI BIOS
- ◆ Graphics Engine
 - Intel® HD Graphics Gen 7 Engine with 4 execution units support DX11.1, OpenGL 4.2 and OpenCL 1.2
- ◆ Display Output
 - Dual independent display
 - 1 x 18/24-bit dual-channel LVDS (up to 1920x1200@60Hz)
 - 1 x DDI (DP up to 2560x1600@60Hz / HDMI up to 1920x1080@60Hz)
- ◆ Ethernet: Intel® I210 GbE controller
- ◆ Embedded Controller: ITE IT8528E/FX
- ◆ I/O Interface
 - 6 x USB 2.0 signal to baseboard
 - 1 x USB 3.0 signal to baseboard
- ◆ Storage
 - 2 x SATA 3Gb/s signal to baseboard
 - Optional soldered-down 4 GB SSD (SATA port 2)
- ◆ Audio
 - High-definition Audio interface to baseboard
- ◆ SMBus: Yes, to baseboard
- ◆ I²C: Yes, to baseboard
- ◆ LPC: Yes, to baseboard
- ◆ SDIO: One 8-bit SDIO 2.0, to baseboard
- ◆ SPI: Yes, to baseboard
- ◆ Serial port: One serial port to baseboard (form EC)
- ◆ Expansion: 3 x PCIe x1 signal to baseboard
- ◆ Watchdog Timer
 - Software programmable supports 1~255 sec. system reset (form EC)
- ◆ Power Consumption
 - 3.3V@0.13A, 5V@0.13A, 12V@1.35A, 5VSB@0.12A (Intel® Atom™ E3845 CPU with 2 GB on-board memory)
- ◆ Operating Temperature: -40°C ~ 85°C
- ◆ Operating Humidity: 5% ~ 95%, non-condensing
- ◆ Dimensions: 70 mm x 70 mm
- ◆ Weight: GW: 300g / NW: 150g

Packing List

| | |
|----------------------------------|----------------|
| 1 x iQ7-BT single board computer | 1 x QIG |
| 1 x Heatsink | 1 x Utility CD |

Ordering Information

| Part No. | Description |
|---------------------|---|
| iQ7-BT-E38451W2-R10 | Qseven Rev. 2.0 module supports Intel® Atom™ processor E3845 (quad core, 10W), on-board 2 GB DDR3L, LVDS, DDI, GbE, SATA 3Gb/s, SDIO, USB 3.0, Audio, -40°C~85°C and RoHS |
| iQ7-BT-E38251W2-R10 | Qseven Rev. 2.0 module supports Intel® Atom™ processor E3825 (dual core, 6W), on-board 2 GB DDR3L, LVDS, DDI, GbE, SATA 3Gb/s, SDIO, USB 3.0, Audio, -40°C~85°C and RoHS |
| iQ7-BT-E38451-R10 | Qseven Rev. 2.0 module supports Intel® Atom™ processor E3845 (quad core, 10W), on-board 2 GB DDR3L, LVDS, DDI, GbE, SATA 3Gb/s, SDIO, USB 3.0, Audio, and RoHS |
| iQ7-BT-E38251-R10 | Qseven Rev. 2.0 module supports Intel® Atom™ processor E3825 (dual core, 6W), on-board 2 GB DDR3L, LVDS, DDI, GbE, SATA 3Gb/s, SDIO, USB 3.0, Audio, and RoHS |
| iQ7-DB-MATX-R10 | Baseboard for Qseven Rev. 2.0 module |

Note: Models with other CPUs not listed in the table are requested by MOQ - 100 pcs/lot.

iQ7-DB-MATX

Baseboard for Qseven Rev. 2.0 Module

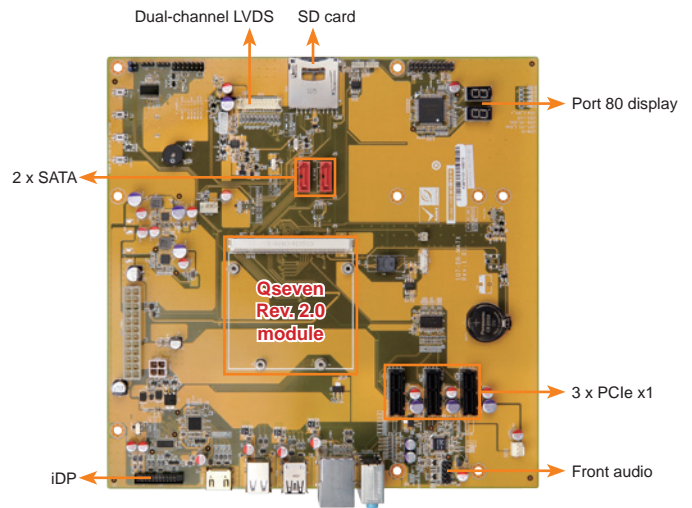

Features

- mATX form factor baseboard for Qseven Rev. 2.0 module
- Supports three PCIe x1
- 18/24-bit dual-channel LVDS

Specifications

- ◆ COM Express Type
 - mATX form factor baseboard for Qseven Rev. 2.0 module
- ◆ Display Interfaces
 - 1 x LVDS
 - 1 x HDMI
 - 1 x iDP
- ◆ Audio
 - Realtek ALC662 HD Audio codec (Line-in, Line-out, Mic)
- ◆ Internal I/O Interface
 - 1 x LPC
 - 1 x SD card socket
 - 2 x SATA port
 - 3 x PCIe x1
- ◆ External I/O Interface
 - 1 x Audio jack (Line-in, Line-out, Mic)
 - 1 x HDMI
 - 1 x USB 3.0
 - 5 x USB 2.0
 - 1 x RJ-45
- ◆ Front Audio
 - 1 x Front audio (2x5 pin)
- ◆ TPM
 - 1 x TPM (2x10 pin)
- ◆ Port 80 Display
 - 2 x 7-segment display
- ◆ Front Panel
 - 1 x Front panel (2x7 pin, power LED, HDD LED, buzzer speaker, power button, reset button)
- ◆ I²C
 - 3 x I²C (1x4 pin)
- ◆ SMBus
 - 1 x SMBus (1x4 pin)
- ◆ Watchdog Timer
 - Software programmable, supports 1~255 sec. system reset
- ◆ Power Supply
 - ATX power supply, ATX/AT mode support
- ◆ Fan Connector
 - 1 x CPU smart fan (1x4 pin)
 - 1 x System fan (1x3 pin)
- ◆ Temperature
 - 40°C ~ 85°C
- ◆ Humidity
 - 5% ~ 95%, non-condensing
- ◆ Dimensions
 - 243.8 mm x 243.8 mm

Packing List

| |
|-----------------------|
| 1 x Qseven® baseboard |
| 1 x QIG |

Ordering Information

| Part No. | Description |
|---------------------|--|
| iQ7-DB-MATX-R10 | Baseboard for Qseven Rev. 2.0 module |
| 32102-000100-200-RS | SATA power cable, MOLEX 5264-4P to SATA15P |

MPCIE-UART-KIT01-R10

PCI Express Mini Card Supports
Quad-port RS-232/422/485, Full Size,
RoHS

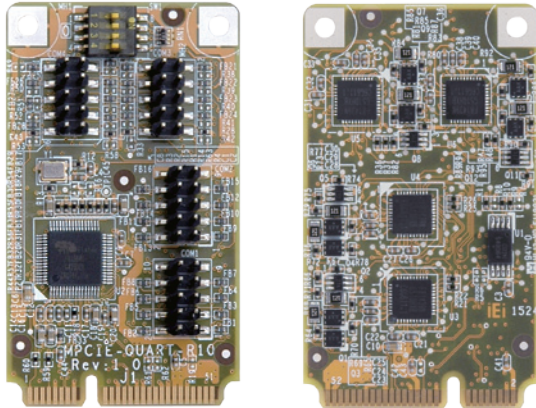

Specifications

- ◆ Form Factor
PCI Express Mini card
- ◆ PCI Express Bridge to Quad Serial Port
Fintek F81504
- ◆ Buffer/Transceiver Series
F81439
- ◆ IO
4 x RS-232/422/485 (2x5-pin header)
- ◆ Operating Temperature
0°C ~ 60°C
- ◆ Operating Humidity
5% ~ 95%, non-condensing
- ◆ Dimensions (LxW)
51 mm x 30 mm
- ◆ Weight
GW: 100g / NW: 50g

Features

- PCI Express Mini supports quad-port RS-232/422/485
- 128 bytes transmit/receive FIFO
- High-speed 16C550/16C650/16C750/16C850 compatible UARTs
- Baud rate supports 115.2K, max. up to 1.5M

New

Dimensions (mm)

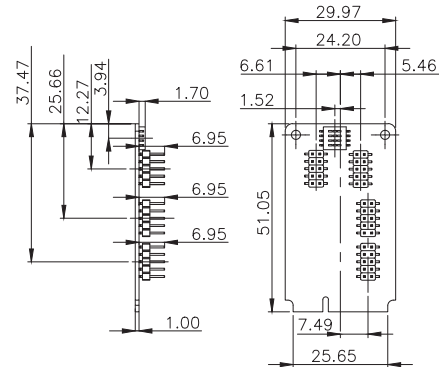

Packing List

| | |
|---------------------------------|---------|
| 1 x MPCIE-UART-KIT01-R10 module | |
| 4 x D-SUB9 male cable | 1 x QIG |

Ordering Information

| Part No. | Description |
|----------------------|--|
| MPCIE-UART-KIT01-R10 | PCI Express Mini card supports quad-port RS-232/422/485, full size, RoHS |

MPCIE-UART-KIT02-R10

PCI Express Mini Card Supports
Dual-port RS-232/422/485, 16-bit
GPIO, Full Size, RoHS

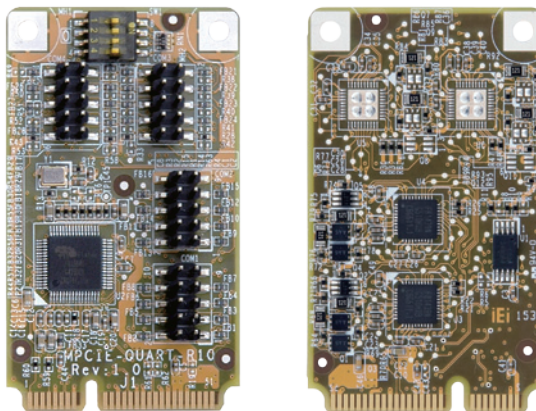

Specifications

- ◆ Form Factor
PCI Express Mini card
- ◆ PCI Express Bridge to Quad Serial Port
Fintek F81504
- ◆ Buffer/Transceiver Series
F81439
- ◆ IO
2 x RS-232/422/485 (2x5-pin header)
2 x 8 bit GPIO (2x5-pin header)
- ◆ Operating Temperature
0°C ~ 60°C
- ◆ Operating Humidity
5% ~ 95%, non-condensing
- ◆ Dimensions (LxW)
51 mm x 30 mm
- ◆ Weight
GW: 100g / NW: 50g

Features

- PCI Express Mini supports dual RS-232/422/485 and 16-bit GPIO ports
- 128 bytes transmit/receive FIFO
- High-speed 16C550/16C650/16C750/16C850 compatible UARTs
- Baud rate supports 115.2K, max. up to 1.5M
- All GPIO supports digit IO for input/output control, output data control, input status
- Support High/Low Level/Pulse, Open Drain/Push Pull function selection

New

Dimensions (mm)

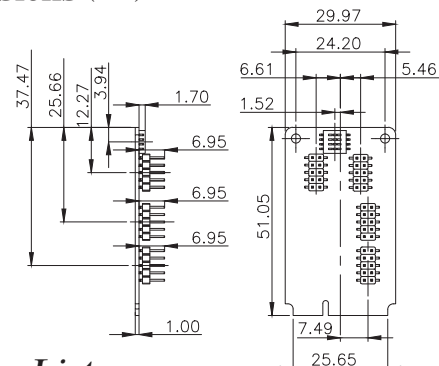

Packing List

| | |
|---------------------------------|---------|
| 1 x MPCIE-UART-KIT02-R10 module | |
| 2 x D-SUB 9 male cable | 1 x QIG |

Ordering Information

| Part No. | Description |
|----------------------|---|
| MPCIE-UART-KIT02-R10 | PCI Express Mini card supports dual-port RS-232/422/485, 16-bit GPIO, full size, RoHS |

1

Industrial
Computing
Solutions

2

Video
Capture
Solutions

3

Industrial
Computer
Chassis

4

Open
Frame
Monitor

5

Power Supply/
Peripherals

6

All-in-One
System

MPCIE-DLAN-R10

PCI Express Mini Dual Intel® GbE LAN Module, Full Size, RoHS

New

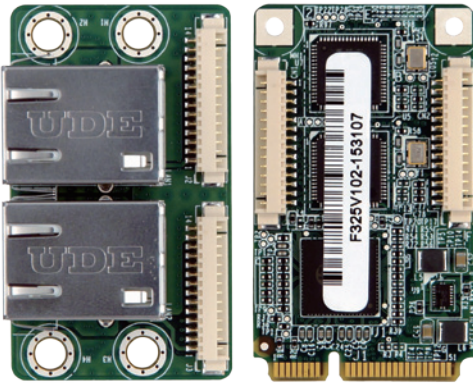

Specifications

- ◆ Form Factor: PCI Express Mini card
- ◆ BIOS: UEFI BIOS
- ◆ Ethernet Controller: Dual Intel® I210-IT
- ◆ Speed: 10/100/1000Mbps
- ◆ External Connector: 2 x 8-pin RJ-45
- ◆ Power Supply: On board 3.3V
- ◆ Compatible OS
Windows XP/Server 2003/ Server 2008/ Vista/ 7 /8.1/10
Linux kernel version 2.6.32 above
- ◆ Operating Temperature: -10°C ~ 70°C
- ◆ Operating Humidity: 5% ~ 95%, non-condensing
- ◆ Dimensions (LxW) : 51 mm x 30 mm
- ◆ Weight: 55g

Dimensions (mm)

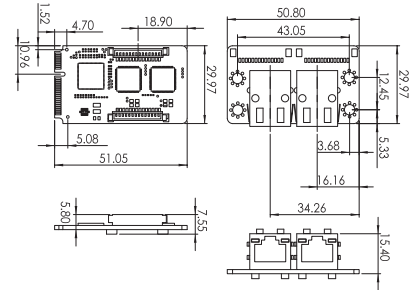

Features

- Support dual GbE LAN by Intel® I210-IT
- Compliant with PCI Express Mini specification 1.2

Packing List

| | | |
|-----------------------|---|---------|
| 1 x MPCIE-DLAN module | 2 x Flat cable (pitch=1.25mm), 340mm length | 1 x QIG |
|-----------------------|---|---------|

Ordering Information

| Part No. | Description |
|----------------|--|
| MPCIE-DLAN-R10 | PCI Express Mini dual Intel® GbE LAN module, full size, RoHS |

MPCIE-LAN-R10

PCI Express Mini GbE LAN Module, Full Size, RoHS

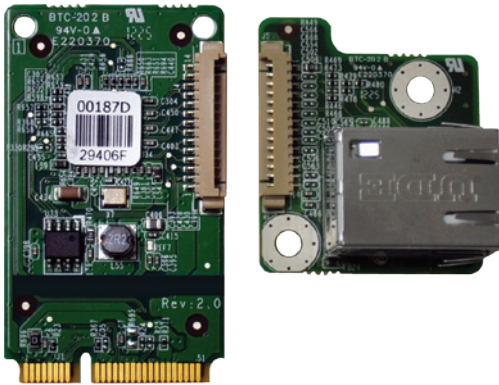

Specifications

- ◆ Form Factor: PCI Express Mini card
- ◆ Display Controller IC: Realtek RTL8111E
- ◆ Speed: 10/100/1000Mbps
- ◆ External Connector: 1 x 8-pin RJ-45
- ◆ Compatible OS
Windows 2000/ XP/ Server 2003/ Server 2008/ Vista/ 7
Linux kernel version 2.6.32 above
- ◆ Power Supply: On board 3.3V
- ◆ Operating Temperature: -10°C ~ 70°C
- ◆ Operating Humidity: 5% ~ 95%, non-condensing
- ◆ Dimensions (LxW) : 51 mm x 30 mm
- ◆ Weight: 70g

Dimensions (mm)

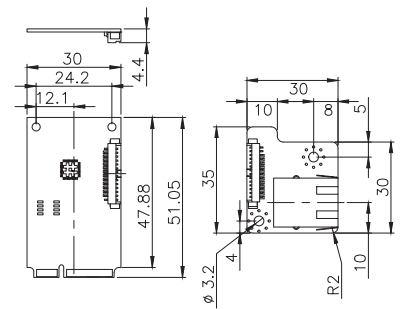

Packing List

| | | |
|----------------------|---|---------|
| 1 x MPCIE-LAN module | 1 x Flat cable (pitch=1.25mm), 340mm length | 1 x QIG |
|----------------------|---|---------|

Ordering Information

| Part No. | Description |
|---------------|--|
| MPCIE-LAN-R10 | PCI Express Mini GbE LAN module, full size, RoHS |

MPCIE-3G-R10

PCI Express Mini 3G Adapter Card, RoHS

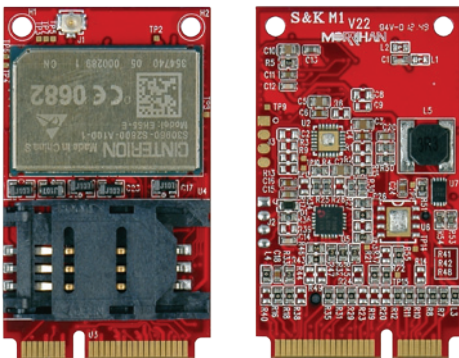

Specifications

- ◆ Form Factor
PCI Express Mini card
Antenna 50Ohms. Main GSM/UMTS antenna
- ◆ USB
USB 2.0 High Speed (480Mbit/s) device interface,
Full Speed (12Mbit/s)
- ◆ Compatible OS
Windows® XP/Vista/7/8
Linux kernel version 2.4.31 above

- ◆ Operating Temperature
Normal operation: -30°C to +85°C
Restricted operation: -40°C to +95°C
- ◆ Dimensions (W x D x H)
50.95 mm x 30 mm x 4.75 mm
- ◆ Frequency Bands
GSM/GPRS/EDGE: Dual band GSM 900/1800 MHz
UMTS/HSPA+: Dual band UMTS 900/2100 MHz

Packing List

| |
|--------------------------------------|
| 1 x PCI Express Mini 3G adapter card |
|--------------------------------------|

Ordering Information

| Part No. | Description |
|---------------------|--|
| MPCIE-3G-R10 | PCI Express Mini 3G adapter card, RoHS |
| 32501-000705-100-RS | RF antenna cable |
| 32503-000100-100-RS | GSM antenna cable |

Features

- Real time clock: Timer functions via AT commands
- Phonebook: SIM and phone
- TTY/CTM support: Integrated CTM modem

1

Industrial
Computing
Solutions

2

Video
Capture
Solutions

3

Industrial
Computer
Chassis

4

Open
Frame
Monitor

5

Power Supply/
Peripherals

6

All-in-One
System

Wireless LAN Module



WMPCIE-V02-R10

PCIe Mini card wireless LAN module

Features

- PCIe Mini card form factor
- High speed wireless connection up to 433.3Mbps transmit/receive PHY rate using 80 MHz bandwidth
- Solid design with external antenna diversity
- Low power consumption and high performance
- Enhanced wireless security
- Fully qualified Bluetooth 4.0 and 3.0 + High speed system

Ordering Information

| Part No. | Description |
|---------------------|---|
| WMPCIE-V02-R10 | IEEE802.11a/b/g/n/ac wireless with Bluetooth 4.0/3.0 + HS PCIe Mini module with Realtek RTL8821AE, RoHS |
| 32501-001000-200-RS | RF cable; 300MM; 28AWG; (A) SMA connector (B) MHF20278-11R-13; ROHS |
| 32505-000100-100-RS | 2 dBi 109mm antenna |
| M32000-102500-RS | USB cable, 2x4pin 2.0mm to JST SHR-06V 1.00mm, L: 150mm |
| M32500-001000-RS | 5 dBi 173mm antenna |



WIFI-RT3593-DB-R10

Features

- Half-size PCIe Mini card
- Dual band 802.11a/b/g/n supports 3Tx/3Rx 3-stream MIMO to enable data rates up to 450Mbps for a 40 MHz channel.
- 20 MHz/40 MHz bandwidth
- Solid design with external antenna diversity
- Low power consumption with advanced power management
- Supports 802.11x authentication, WEP 64/128, WPA, WPA2, WAPI encryption.
- Supported operating systems: Windows® XP, 2000, ME, 98SE, Vista 32/64, Linux, MAC

Ordering Information

| Part No. | Description |
|---------------------|---|
| WIFI-RT3593-DB-R10 | Wi-Fi module with RT3593 single chip, 3T3R, dual band, RoHS |
| 32501-000200-100-RS | Antenna; RF cable; outside diameter: 1.13mm; L=128mm; 0-6 GHz; (A)reverse sma jack, nut *1+washer *2; (B)I-PEX; RoHS |
| 32505-000900-100-RS | External antenna; WLAN; RG 178; 108mm; TANK-700-QM67-R10; PEAK GAIN 2.0DBI; Exceltek; 2.4-2.5 GHz/5.15-5.85 GHz; reverse SMA plug; RoHS |

Specifications

| Model | WMPCIE-V02-R10 |
|---------------------------|--|
| Standards | IEEE 802.11a/b/g/n/ac Wi-Fi with Bluetooth 4.0/3.0 + HS (Wi-Fi:PCI-E, BT:USB) |
| Interface | PCIe Mini card |
| Connectors | 2XU.FL(I-PEX) antenna connectors |
| Controller Chip | Realtek RTL8821AE |
| Frequency Range | Wi-Fi: 2.4/5GHz, BT: 2402 MHz~2483 MHz |
| Modulation Type | Wi-Fi: 802.11a/g/n/ac: OFDM 802.11b: CCK, DQPSK, BPSK BT: Header GFSK Payload 2M: 4-DQPSK Payload 3M: 8DPSK |
| Supported OS | Windows 7/8/10 |
| Receiver Sensitivity | Wi-Fi: 802.11a: less than -65 dBm (54M) 802.11b: less than -76 dBm (11M) 802.11g: less than -65 dBm (54M) 802.11n@2.4GHz: less than -64 dBm (HT20 MCS7) 802.11n@5GHz: less than -64 dBm (HT20 MCS7) 802.11ac@5GHz: less than -51 dBm (VHT80 MCS9) BT: BER < 0.1% (Anritsu 8852B Tx -70 dBm) |
| Temperature | Operating: 0°C ~ 70°C Storage: -40°C ~ 85°C |
| Humidity | 5% ~ 95%, non-condensing |
| Dimensions | 29.85mm x 26.65mm |
| Weight | NW: 3.28g |
| Compliance Certifications | FCC, CE |

Specifications

| Model | WIFI-RT3593-DB-R10 |
|------------------------|---|
| Standards | IEEE 802.11a/b/g/n, Wi-Fi compliant |
| Rate | 450 Mbps PHY rate in 3T3R mode |
| Interface | PCIe Mini card |
| Controller Chip | Ralink RT3593 |
| Connectors | 3 x U.FL (I-PEX) antenna connectors |
| Security | WEP 64/128, WPA, WPA2, WAPI |
| Frequency Range | 2.4/5GHz |
| Modulation Type | 802.11a (OFDM) 802.11b (DSSS): CCK, DQPSK, DBPSK 802.11g (OFDM): BPSK, QPSK, 16-QAM, 64-QAM 802.11n (OFDM): BPSK, QPSK, 16-QAM, 64-QAM |
| Supported OS | Windows® XP, CE6.0, XPE, 2000, ME, 98SE, Vista 32/64, Windows® 7 32/64, MAC |
| Receiver Sensitivity | 802.11a: -71dBm (Typical) at 54 Mbps 802.11b: -80dBm (Typical) at 11 Mbps 802.11g: -73dBm (Typical) at 54 Mbps 802.11n: -71dBm (Typical) at 450 Mbps |
| Power Consumption | 430mA@3.3V in continuous Tx 460mA@3.3V in continuous Rx |
| Temperature | Operating: -10°C ~ 70°C Storage: -40°C ~ 150°C |
| Humidity | Operating: 5% ~ 95%, non-condensing |
| Dimensions (W x D x H) | 28 mm x 30 mm x 4 mm |
| Weight | NW: 11g |
| Safety & EMC | CE/FCC/TELEC |

1

Industrial
Computing
Solutions

2

Video
Capture
Solutions

3

Industrial
Computer
Chassis

4

Open
Frame
Monitor

5

Power Supply/
Peripherals

6

All-in-One
System

IGCME-1300-R11

PCIe Mini VGA Adapter Card, RoHs

IEI Scalable Display Solution

The IGCME-1300 is applied to expand one VGA port for the IEI motherboard with a PCIe Mini slot for multiple display applications.

Features

- Support PCIe VGA/2D controller, 1920x1200@60Hz 32bpp
- DDR3 SDRAM supports up to 800 MHz speed
- Compliant with PCI Express Mini specification 1.2

Specifications

- ◆ Form Factor
PCI Express Mini card
- ◆ Display Controller
Aspeed AST1400
- ◆ Internal Connector
1 x 10-pin (2x5) box header by 2.0mm pitch
- ◆ Compatible OS
Win7/Win8/Server 2003/Server 2008/Server 2012
Linux kernel version 2.6.32 above
- ◆ Power Supply
On-board 3.3V
- ◆ Operating Temperature
-10°C ~ 60°C
- ◆ Operating Humidity
5% ~ 95%, non-condensing
- ◆ Dimensions (LxW)
50mm x 30mm
- ◆ Weight
70g

Packing List

| | |
|---|---------|
| 1 x IGCME-1300 PCIe Mini VGA adapter card | 1 x QIG |
| VGA cable, 600 mm length (Pitch=2.0mm) (P/N: 32003-001500-100-RS) | |

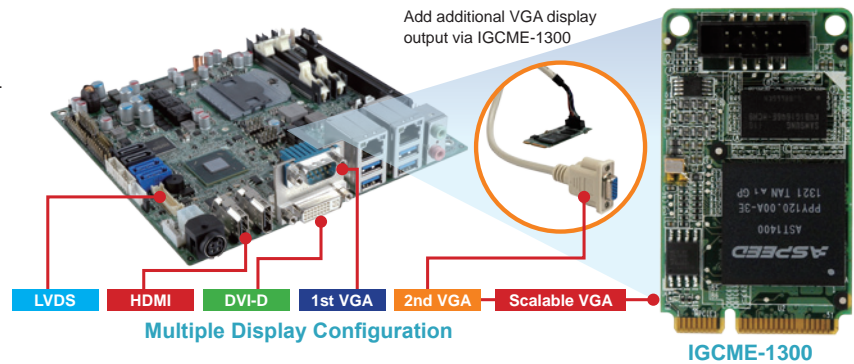

Dimensions (mm)

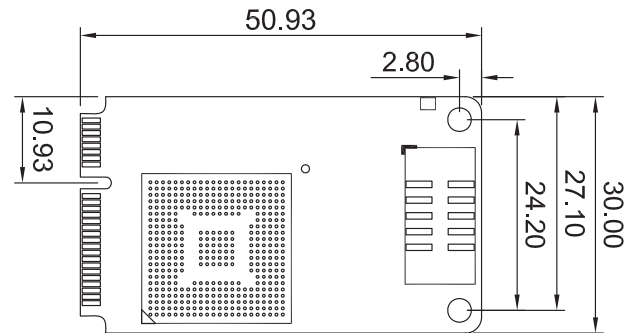

Ordering Information

| Part No. | Description |
|----------------|----------------------------------|
| IGCME-1300-R11 | PCIe Mini VGA adapter card, RoHs |

MPCIE-USB3

PCIe Mini USB 3.0 Adapter Card, RoHs

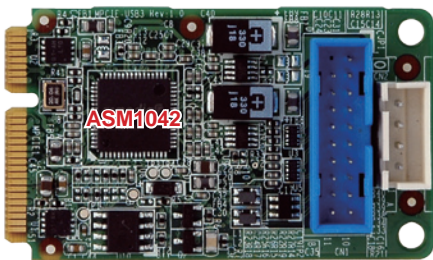

IEI USB 3.0 Expanded Solution

The MPCIE is applied to add additional super speed USB 3.0 ports for the motherboard with a PCIe Mini slot.

Motherboard with PCIe Mini Slot

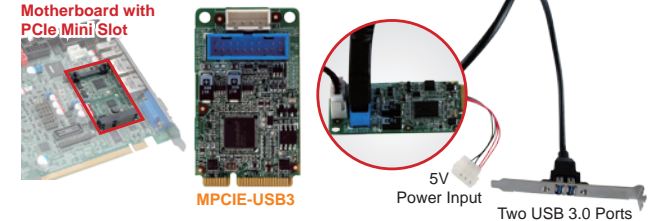

Specifications

- ◆ Form Factor
PCI Express Mini card
- ◆ USB 3.0 Controller
Asmedia ASM1042A
- ◆ Internal Connector
1 x 20-pin (2x10) box header
- ◆ Power Jack
1 x 4-pin box header
- ◆ Compatible OS
Windows® 2000/XP/Server 2003/Server 2008/Vista/7
Linux kernel version 2.6.32 above
- ◆ Operating Temperature
-10°C ~ 60°C
- ◆ Operating Humidity
5% ~ 95%, non-condensing
- ◆ Dimensions (LxW)
50 mm x 30 mm
- ◆ Weight
70g

Packing List

| | |
|---|---------|
| 1 x MPCIE-USB3 PCIe Mini USB 3.0 adapter card | |
| 1 x Dual USB 3.0 type A port cable with bracket | |
| 1 x Power cable | 1 x QIG |

Ordering Information

| Part No. | Description |
|---------------------|---|
| MPCIE-USB3-R11 | PCIe Mini USB 3.0 adapter card, RoHs |
| 19800-010500-200-RS | Dual USB 3.0 type A port cable with bracket |

Features

- Supports two external USB 3.0 type A ports
- USB 3.0 provides up to 5Gbps of transferring rate
- Backward compatible with USB 2.0 and USB 1.0/1.1 devices
- Fully compliant with USB 3.0 rev 1.0 specifications and Intel® xHCI rev 0.96 specifications, with transfer rates up to 5Gbps
- Compliant with PCI Express Mini specification 1.2

Dimensions (mm)

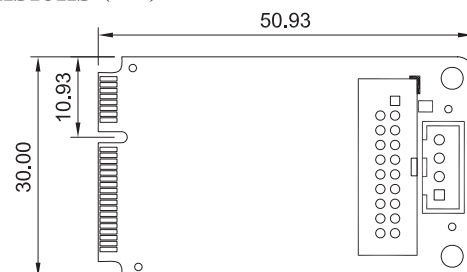

1

Industrial
Computing
Solutions

2

Video
Capture
Solutions

3

Industrial
Computer
Chassis

4

Open
Frame
Monitor

5

Power Supply/
Peripherals

6

All-in-One
System

IEI Trusted Platform Module (TPM)

Hardware-based security solution for data protection and reliable authentication via TPM that stores key, passwords and digital certificates.

H/W Features

| | | |
|----------------------------------|--|---------------------|
| Solution | Infineon SLB9635 TT1.2 | SLB9665TT2.0 |
| Features | | |
| Secure Startup | Root of Trust Measurement of early boot devices | |
| Anti H/W Attack | Sensors and active shield | |
| TSS API Support | MS-CAPI/PKCS#11, #12 | |
| H/W Certification | | |
| Management Tool Function | 1. TPM management 2. File & Folder En/De-cryption 3. Personal secure drive 4. Secure Email 5. Key transferring 6. Security policy configuration | |
| Market Segment | Complete TPM1.2/2.0 function | |
| TCG Specification | TCG 1.2/2.0 compliant trusted platform module | |
| Interface | Low pin count | |
| Software Structure | TCG software stack 1.2 complaint | |
| Cryptographic Accelerator | HAS-1/RSA algorithm | |

IEI SBC with TPM support

| Form factor | Model name | Form factor | Model name |
|-----------------|--------------------|-------------|-----------------|
| PICMG1.3 | PCIE-Q170-i2* | Micro-ATX | IMB-H110* |
| | SPCIE-C236-i2* | | IMB-Q870-i2 |
| | SPCIE-C2260-i2 | | IMB-H810-i2 |
| | SPCIE-C2160 | | IMB-Q770 |
| | SPCIE-C2060 | | IMB-Q670 |
| | PCIE-H810 | | IMB-H610A/H610B |
| | PCIE-Q670 | | tKINO-BW |
| PICMG1.0 | PCIE-H610 | Mini-ITX | KINO-DBT |
| | WSB-H810 | | KINO-SE/KBN-i2 |
| | WSB-H610 | | KINO-DH810 |
| Half-size PCIe | WSB-PV-D4251/D5251 | | eKINO-BT |
| | PICOe-B650 | | KINO-ABT-i2 |
| Half-size PCISA | PICOe-HM650 | | KINO-DA750-i2 |
| | PCISA-BT | | KINO-AA750-i2 |
| ATX | IMBA-C2360-i2* | | KINO-AQ870 |
| | IMBA-Q170-i2* | | KINO-DQM871-i1 |
| | IMBA-H110* | | KINO-QM770 |
| | IMBA-BDE | KINO-DH610 | |
| | IMBA-H810 | KINO-AH611 | |
| | IMBA-C2260-i2 | KINO-AH612 | |
| | IMBA-Q870-i2 | KINO-QM670 | |
| | IMBA-Q770 | 5.25" SBC | NOVA-PV-D5251 |
| | IMBA-H610 | EPIC SBC | NANO-QM871 |
| | IMBA-C2060 | | NANO-QM770 |
| IMBA-Q670 | NANO-HM650 | | |

Pin Assignment

| Pin | Signal | Pin | Signal | Pin | Signal | Pin | Signal |
|-----|---------|-----|--------|-----|--------|-----|---------|
| 1 | LCLK | 6 | VCC5 | 11 | LAD0# | 16 | SERIRQ |
| 2 | GND | 7 | LAD3# | 12 | GND | 17 | GND |
| 3 | LFRAME# | 8 | LAD2# | 13 | SCL | 18 | CLKRUN# |
| 4 | KEYWAY | 9 | VCC3 | 14 | SDA | 19 | LPCPD# |
| 5 | LRST# | 10 | LAD1# | 15 | SB3V | 20 | LDRQ# |

* TPM 2.0 is supported in these models.

Ordering Information

| Model Name | Description |
|--------------|---|
| TPM-IN01-R20 | 20-pin Infineon TPM1.2 module, software management tool, firmware v3.17 |
| TPM-IN02-R20 | 20-pin Infineon TPM2.0 module, software management tool, firmware v5.5 |

Dimensions (mm)

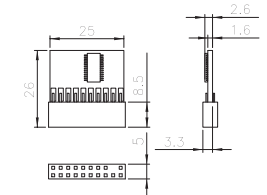

1

Industrial Computing Solutions

2

Video Capture Solutions

3

Industrial Computer Chassis

4

Open Frame Monitor

5

Power Supply/Peripherals

6

All-in-One System

IPCIE-4POE

PCI Express Power over ethernet frame grabber card, 4-port 1000 Base(T), 802.3af compliant

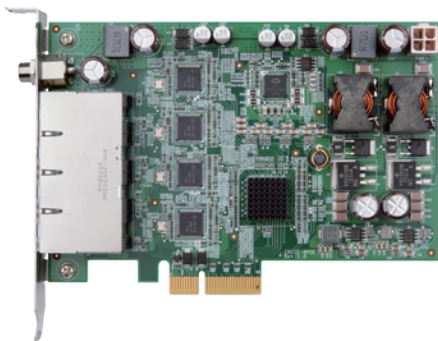

Features

- PCI Express® x4 compliant
- Support for IEEE 802.3af for PoE (Power over Ethernet) with 15.4 watts per port
- Support link aggregation/jumbo frames (9 Kbyte)
- Supports 12~24 AT/ATX DC input power.

Packing List

- 1 x IPCIE-4POE card
- 1 x QIG
- 1 x Utility CD

Dimensions (mm)

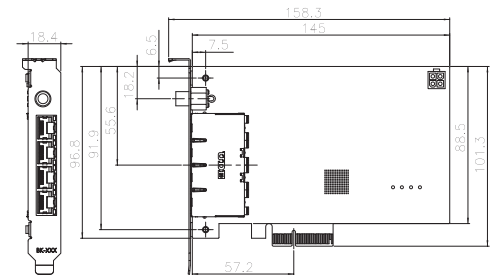

Specifications

- ◆ Interface: PCI Express® x4
- ◆ Ethernet Intel® i210 AT controller 9kB jumbo frame IEEE 802.3az, IEEE1588
- ◆ PoE Capability IEEE 802.3af 15.4W / 48V DC per port
- ◆ PWR Input 12~24V DC input Internal DC input (2x2 ATX) External DC input (Φ2.1/Φ5.5)
- ◆ Operating Temperature: 0°C ~ 60°C
- ◆ Storage Temperature: -10°C ~ 70°C
- ◆ Operating Humidity: 5% ~ 95%, non-condensing

Ordering Information

| Part No. | Description |
|---------------------|---|
| IPCIE-4POE-R10 | PCI Express power over ethernet frame grabber card, 4-port 1000 Base(T), 802.3af compliant |
| 63040-010090-120-RS | Adapter power, FSP, FSP090-DIEBN2, 9NA0904712, Vin: 90~264VAC, 90W, Plug=7.5mm, Cable=1500mm, Erp (no load 0.5W), Vout: 19VDC, Φ2.1/Φ5.5/lock, CCL, RoHS |
| 63040-010065-200-RS | Adapter power, FSP, FSP065-REBN2, 9NA0654709, Vin: 90~264VAC, 65W, Dim: 46.3x108.3x30mm, Plug=7.5mm, Cable=1500mm, Erp (no load 0.1W), Vout: 19VDC, Φ2.1/Φ5.5/lock, CCL, RoHS |

SATA to CFast™ Converter Board

SACFA-KIT01-R10

SATA to CFast™ converter board

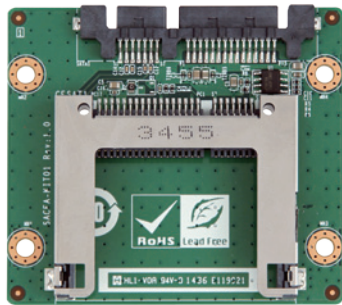

32801-000100-300-RS

Dimensions (Unit: mm)

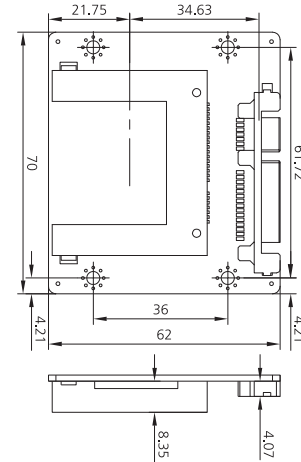

Features

- CFast™ socket
- 7-pin SATA data connector, and a female 17-pin power CFast™ connector

Packing List

| |
|---------------------|
| 1 x SACFA-KIT01-R10 |
| 1 x QIG |

Ordering Information

| Part No. | Description |
|---------------------|--|
| SACFA-KIT01-R10 | SATA to 24-pin CFast™ socket converter board |
| 32000-080700-RS | SATA 7+15P female to SATA 7P / PH 5.08 4P cable, L=200mm/100mm |
| 32801-000100-100-RS | SATA 7+15P female to SATA 7P / PH 2.5 4P cable, L=200mm/200mm |
| 32801-000201-100-RS | SATA 7+15P female to SATA 7P / PH 2.0 2P cable, L=150mm/150mm |

SATA to CF Type II Converter Board

SACF-KIT01-R10

SATA to CF converter board

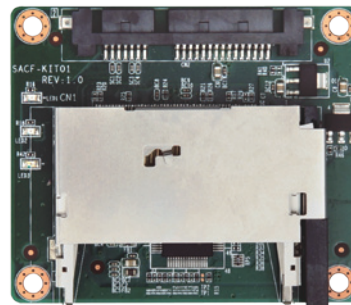

32801-000100-300-RS

Dimensions (Unit: mm)

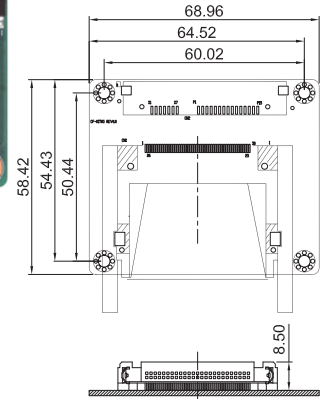

Features

- CF Type II socket
- 50-pin CF Type II connector

Packing List

| | |
|-------------------------------|---------|
| 1 x SACF-KIT01-R10 | 1 x QIG |
| 1 x SATA with power cable kit | |

Ordering Information

| Part No. | Description |
|----------------|--|
| SACF-KIT01-R10 | SATA to 50-pin CF socket converter board |

1 Industrial Computing Solutions

SATA to IDE/CF Type II Converter Board

SAIDE-KIT01-R10

SATA to IDE/CF converter board

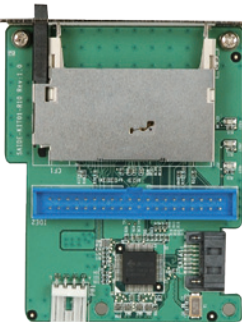

32100-064401-RS

Dimensions (Unit: mm)

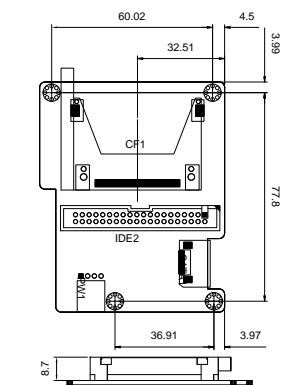

Features

- CF Type II socket
- 40-pin IDE connector (master mode)
- 4-pin 5V input connector
- Power/5V/HDD LED indicator
- Support one IDE device or one CF

Packing List

| | |
|---------------------|---------|
| 1 x SAIDE-KIT01-R10 | 1 x QIG |
| 1 x Power cable | |

Ordering Information

| Part No. | Description |
|---------------------|---|
| SAIDE-KIT01-R10 | SATA to 40-pin IDE/CF socket converter board with bracket |
| 32000-062800-RS | SATA cable |
| 32100-064401-RS | Power cable |
| 32102-000100-200-RS | SATA power cable |

2 Video Capture Solutions

3 Industrial Computer Chassis

4 Open Frame Monitor

5 Power Supply/Peripherals

6 All-in-One System

IDE/CF Type II Converter Board

CF-KIT04-R10 IDE to CF Type II converter board with master/slave mode selection



Features

- CF Type II socket with master/slave mode selection
- 4-pin power connector
- Power/HDD signal LED

Dimensions (Unit: mm)

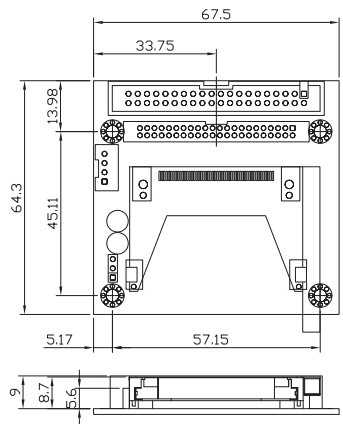

IEI CF Solution



iCF1000 Industrial standard grade



iCF1000 Wide Temp. grade

IEI iDP Introduction

iDP (IEI Internal DisplayPort)

The iDP connector is provided on the IEI 8-series products. Through the IEI iDP converter cards, the iDP connector can support different display specifications, such as VGA, HDMI, DVI-D and LVDS.

| Model | Output | External Power |
|-------------|--------|----------------|
| DP-VGA-R10 | VGA | No |
| DP-HDMI-R10 | HDMI | No |
| DP-DVI-R10 | DVI | No |
| DP-LVDS-R10 | LVDS | Yes |
| DP-DP-R10 | DP | No |

| iDP Supported Models | |
|----------------------|--------------|
| SPCIE-C2260-i2 | IMB-H810-i2 |
| PCIE-Q870-i2 | KINO-DQM871 |
| IMBA-Q870-i2 | KINO-DH810 |
| IMBA-C2260-i2 | WAFER-ULT-i1 |
| IMB-Q870-i2 | WAFER-KBN-i1 |

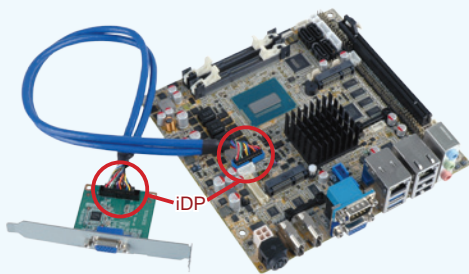

Flexible Display Output Options

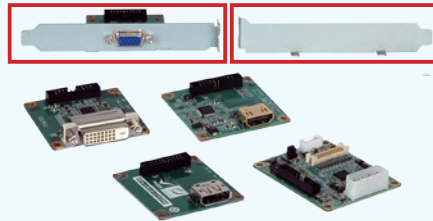

iDP converter cards with brackets
Easy Installation on the Chassis

DP-DP-R10

DisplayPort Expansion Board (for IEI iDP Connector), RoHS

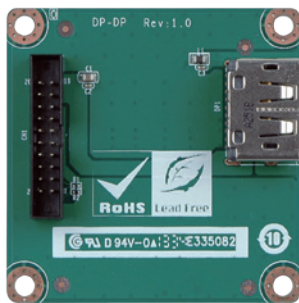

Features

- DisplayPort output

Specifications

- ◆ Display Input: 1 x IEI iDP connector
- ◆ Display Output: 1 x DisplayPort
- ◆ Temperature: -20°C ~ 60°C
- ◆ Humidity: 5 ~ 95% non-condensing
- ◆ Dimensions: 50 mm x 50 mm

Dimensions (mm)

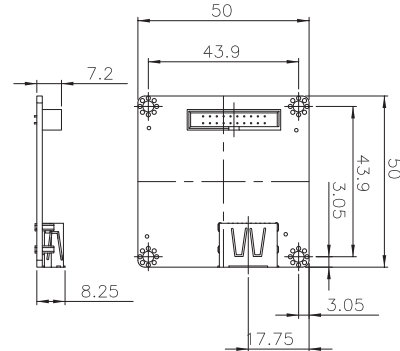

Packing List

| | |
|--|---------|
| 1 x DP-DP expansion board | 1 x QIG |
| 1 x IEI iDP connector cable, 450 mm length | |

Ordering Information

| Part No. | Description |
|-----------|---|
| DP-DP-R10 | DisplayPort expansion board (for IEI iDP connector), RoHS |

DP-HDMI-R10

DisplayPort to HDMI 1.3a Converter Board (for IEI iDP connector), RoHS

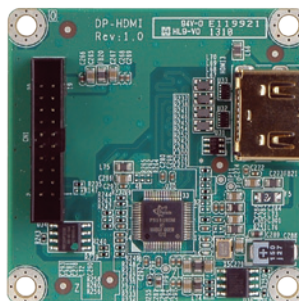

Features

- DisplayPort to HDMI 1.3a output
- Support up to 1920x1200 resolution

Specifications

- ◆ Display Input: IEI iDP connector
- ◆ Display Output: 1 x HDMI 1.3a
- ◆ Display IC: Parade - PS161 (DP to HDMI 1.3a)
- ◆ Temperature: -10°C ~ 60°C
- ◆ Humidity: 5 ~ 95% non-condensing
- ◆ Dimensions: 50 mm x 50 mm

Dimensions (mm)

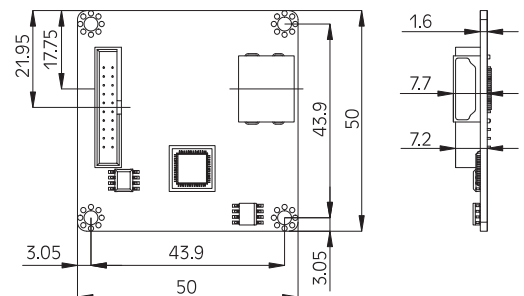

Packing List

| | |
|---|---------|
| 1 x DP-HDMI converter board | 1 x QIG |
| 1 x Internal DisplayPort cable, 450 mm length | |

Ordering Information

| Part No. | Description |
|-------------|--|
| DP-HDMI-R10 | DisplayPort to HDMI 1.3a converter board (for IEI iDP connector), RoHS |

1

Industrial
Computing
Solutions

2

Video
Capture
Solutions

3

Industrial
Computer
Chassis

4

Open
Frame
Monitor

5

Power Supply/
Peripherals

6

All-in-One
System

DP-LVDS-R10

DisplayPort to 24-bit Dual-channel LVDS Converter Board
(for IEI iDP Connector), RoHS

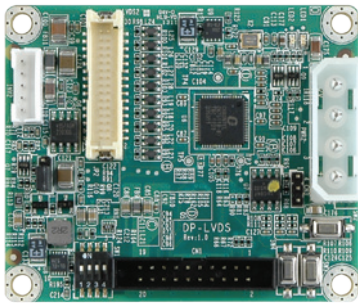

Features

- DisplayPort to LVDS output
- Supports 24-bit dual-channel up to 1920x1200

Specifications

- ◆ Display Input: 1 x IIEI iDP connector
- ◆ Display Output: 1 x LVDS 24-bit dual-channel
- ◆ Display IC: Chrontel - CH7511B (DP to LVDS)
- ◆ Temperature: -10°C ~ 60°C
- ◆ Humidity: 5% ~ 95 non-condensing
- ◆ Dimensions: 60 mm x 50 mm

Dimensions (mm)

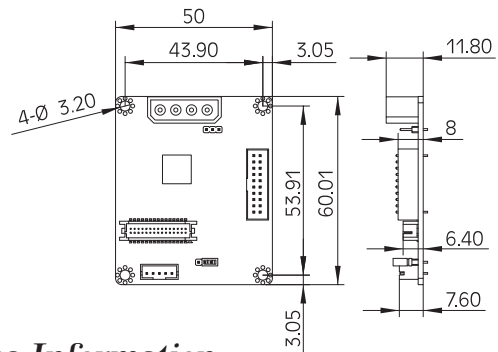

Packing List

| | |
|---|---------|
| 1 x DP-LVDS converter board | 1 x QIG |
| 1 x Internal DisplayPort cable, 450 mm length | |

Ordering Information

| Part No. | Description |
|-------------|--|
| DP-LVDS-R10 | DisplayPort to 24-bit dual-channel LVDS converter board (for IIEI iDP connector), RoHS |

DP-VGA-R10

DisplayPort to VGA Converter Board (for IIEI iDP Connector),
RoHS

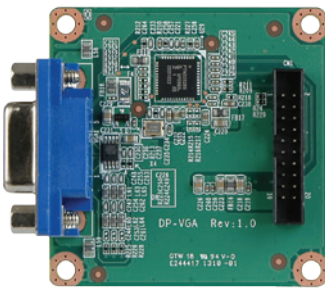

Features

- DisplayPort to VGA output
- Support up to 1920x1200 resolution

Specifications

- ◆ Display Input: 1 x IIEI iDP connector
- ◆ Display Output: 1 x VGA
- ◆ Display IC: NXP - PTN3392 (DP to VGA)
- ◆ Temperature: -10°C ~ 60°C
- ◆ Humidity: 5% ~ 95 non-condensing
- ◆ Dimensions: 50 mm x 50 mm

Dimensions (mm)

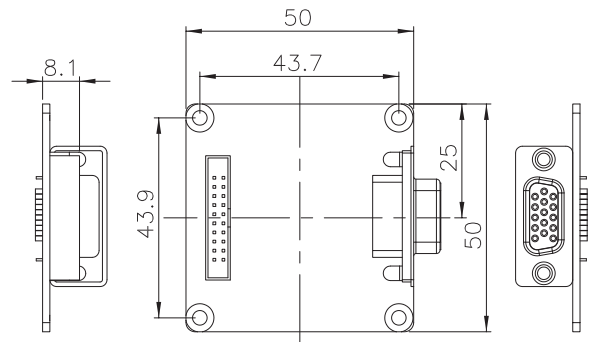

Packing List

| | |
|---|---------|
| 1 x DP-VGA converter board | 1 x QIG |
| 1 x Internal DisplayPort cable, 450 mm length | |

Ordering Information

| Part No. | Description |
|------------|---|
| DP-VGA-R10 | DisplayPort to VGA converter board (for IIEI iDP connector), RoHS |

DP-DVI-R10

DisplayPort to DVI Converter Board (for IIEI iDP Connector),
RoHS

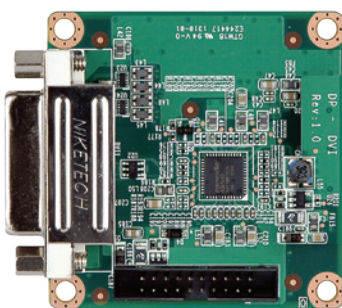

Features

- DisplayPort to DVI output
- Support up to 1920x1200 resolution

Specifications

- ◆ Display Input: 1 x IIEI iDP connector
- ◆ Display Output: 1 x DVI
- ◆ Display IC: Parade - PS161 (DP to HDMI / DVI)
- ◆ Temperature: -10°C ~ 60°C
- ◆ Humidity: 5% ~ 95 non-condensing
- ◆ Dimensions: 50 mm x 50 mm

Dimensions (mm)

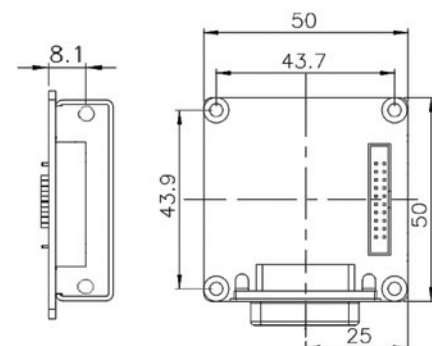

Packing List

| | |
|---|---------|
| 1 x DP-DVI converter board | 1 x QIG |
| 1 x Internal DisplayPort cable, 450 mm length | |

Ordering Information

| Part No. | Description |
|------------|---|
| DP-DVI-R10 | DisplayPort to DVI converter board (for IIEI iDP connector), RoHS |

1

Industrial
Computing
Solutions

2

Video
Capture
Solutions

3

Industrial
Computer
Chassis

4

Open
Frame
Monitor

5

Power Supply/
Peripherals

6

All-in-One
System

LVDS-DVI

18-bit LVDS to DVI Converter Board, Resolution Support up to 1366x768 (Support IEI Model Only)

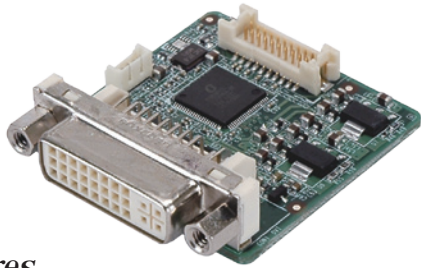

Dimensions (mm)

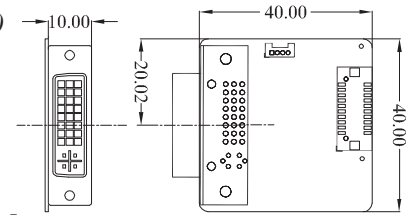

Features

- Provide DVI option for dual display output
- Resolution supported: 1366x768, 1024x768, 800x600, 640x480
- 18 or 24-bit LVDS to DVI converter board

Supported Models

| | | |
|---------------|----------------|----------------|
| WSB-PV-D5251 | PIC0e-PV-D5251 | PCISA-PV-D5251 |
| KINO-PV-D5252 | NOVA-PV-D5251 | NANO-PV-D5251 |
| NANO-PV-D5252 | WAFER-PV-D5252 | |

Packing List

- 1 x LVDS to DVI converter board
- 1 x SMBus cable
- 1 x QIG

Ordering Information

| | |
|---------------------|--|
| LVDS-DVI-R10 | 18/24-bit LVDS to DVI converter board |
| 32602-012200-100-RS | 20-pin to 30-pin LVDS connecting cable for WAFER-PV-D5252 only |
| 32602-012300-100-RS | 20-pin to 20-pin LVDS connecting cable |

LVDS-VGA-R10

Single-channel LVDS to VGA Converter Board (Support IEI Model Only)

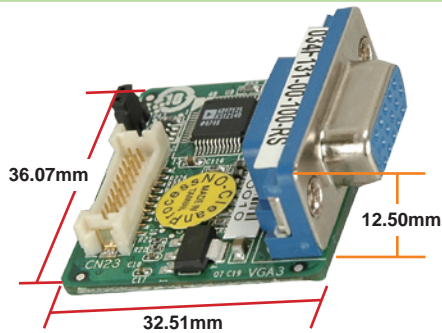

Dimensions (mm)

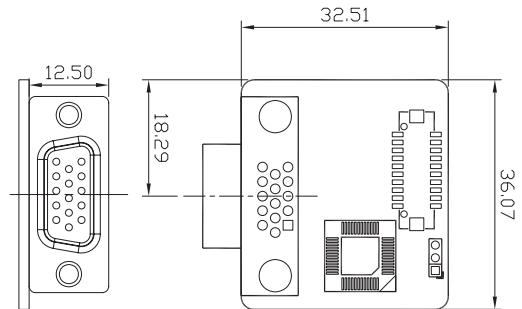

Features

- Provide 2nd VGA option for dual VGA display
- Resolution adjusted by BIOS: Support 1024x768, 800x600, 640x480
- 18-bit LVDS to VGA converter board

Ordering Information

| Part No. | Description |
|---------------------|------------------------------------|
| LVDS-VGA-R10 | 18-bit LVDS to VGA converter board |
| 32600-112300-RS | 30-pin LVDS connecting cable |
| 32602-026400-100-RS | 20-pin LVDS connecting cable |

Packing List

- 1 x LVDS to VGA converter board
- 1 x QIG

LVDS24-01

18-bit to 24-bit LVDS Converter Board

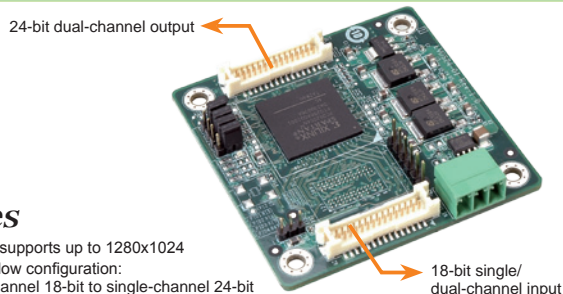

Dimensions (mm)

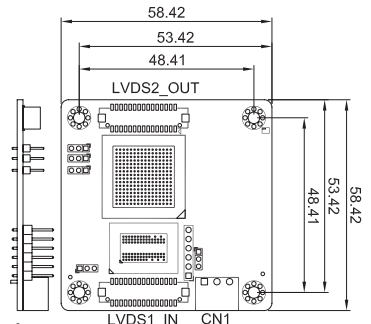

Features

- Resolution supports up to 1280x1024
- Support below configuration:
 - » Single-channel 18-bit to single-channel 24-bit
 - » Single-channel 18-bit to dual-channel 24-bit
 - » Dual-channel 18-bit to dual-channel 24-bit
- * Note: The module does not support dual-channel 18-bit to single-channel 24-bit conversion.

Ordering Information

| Part No. | Description |
|---------------------|---|
| LVDS24-01-R10 | 18-bit to 24-bit LVDS converter board |
| 32602-007900-100-RS | Single-channel 18-bit 20-pin to 24-bit 30-pin LVDS connection cable |
| 32602-008000-200-RS | Dual-channel 18-bit 30-pin to 24-bit 30-pin LVDS connection cable |

Packing List

- 1 x 18-bit to 24-bit LVDS converter board
- 1 x Power cable
- 1 x QIG

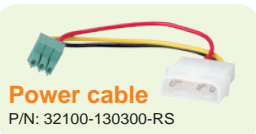

PM-1004/1028-8

4-port Non-isolated RS-232/422/485 Serial Communication PC/104 Module

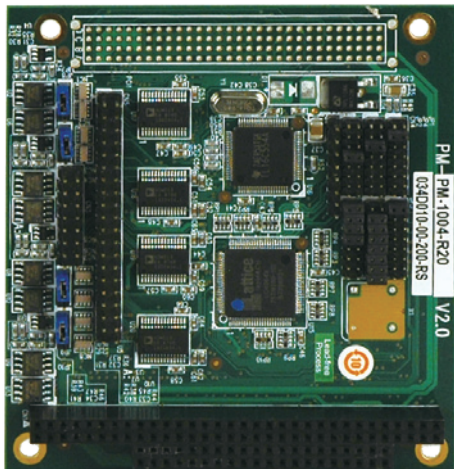

PM-1004

4-port/8-port non-isolated RS-232 serial communication PC/104 modules

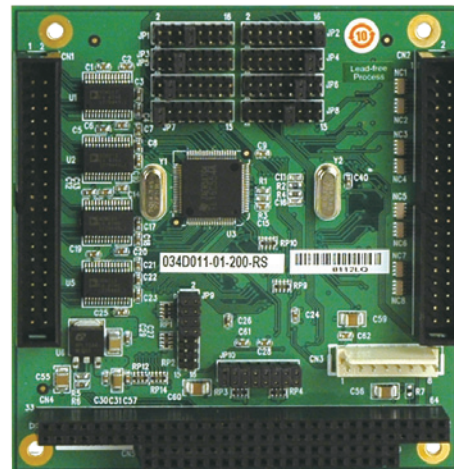

PM-1028



P/N: 32205-002500-100-RS

Shipped with 4-port RS-422/485 connection cable

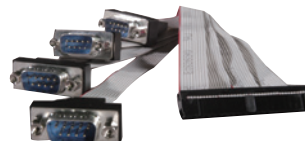

P/N: 32205-001201-100-RS

Shipped with 4-port RS-232 connection cable

Features

- PC/104 form factor
- 16C554 UART controller
- Four jumpers for RS-232 or RS-422/485 serial communication selection
- Supports shared IRQ or independent IRQ mode
- Jumper selectable interrupt level
- Max. baud rate: 921.6kb/s
- Windows® NT, Windows® 2000, Windows® XP, Windows® CE and Linux driver support

Specifications

| | PM-1004 | PM-1028-8 |
|---|--|-------------------|
| Bus Interface | PC/104 | |
| Number of Ports | 4-port | 8-port |
| Interrupt Level | 3, 4, 5, 7, 9, 10, 11, 12 | |
| Chipset | TI 16C554A | |
| Baud Rate | 921.6 Kbps (max.) at 14.745 MHz clock input | |
| Serial Port | 16C550-compatible UARTs | |
| Connectors (40-pin; 2.54 box header) | 1 x 4-port RS-232/RS-422/RS-485 | 2 x 4-port RS-232 |
| Power Consumption | +5V @ 0.6A (max.) | |
| Operating Temperature | 0°C ~ 60°C | |
| Dimensions | 96 mm x 90 mm | |
| Driver Support | Windows®NT, Windows®2000, Windows®XP, Windows®CE and Linux | |

Packing List

- 1 x 4-port non-isolated RS-232/422/485 serial communication PC/104 module
- 1 x 4-port RS-422/485 connection cable
- 1 x RS-232 cable
- 1 x Mini jumper pack
- 1 x Utility CD

Ordering Information

| Part No. | Description |
|---------------|---|
| PM-1004-R20 | 4-port non-isolated RS-232/422/485 serial communication PC/104 module |
| PM-1028-8-R20 | 8-port non-isolated RS-232 serial communications PC/104 module |